



X Sport

User Guide

X Sport User Guide

Part Number: 29K-071471-7E

Refers to X Sport code 2.25

September 2005

Pi and the Pi logo are trademarks of Pi Group Limited

© Pi Research 2004, 2005



Disclaimer

Pi Research makes no representation or warranties of any kind whatsoever with respect to the contents hereof and specifically disclaims any implied warranties of merchantability or fitness for any particular purpose. Pi Research shall not be liable for any errors contained herein or for incidental or consequential damages in connection with the furnishing, performance or use of the software, associated hardware, or this written material.

Pi Research reserves the right to revise this publication from time to time, and to make changes in the content hereof without obligation to notify any person of such revision or changes.

A copy of the Pi Research Terms and Conditions of Sale is available on request, and includes a declaration of the warranty and limitation of liability which apply to all Pi Research products and services.

Health and Safety information

Under the terms of European and UK Health and Safety Legislation, Pi Research is required to classify any hazardous materials in the products it supplies and to provide relevant safety information to users.

Any hazardous materials in Pi products are clearly marked with appropriate symbols. Product Safety Data Sheets relating to these materials are available on request.

Contents

Overview

Introduction	11
RPM input	11
Part numbers	12
Declaration of Conformity	14
Conditions Of Use	15
Overview	19
Introduction	19
The X Sport	19
Telltale	20
Alarms	20
Club qualifying mode	21
The beacon receiver	21
Outings Report Manager software	22
Conventions	23
Display field use	23
Button functions	25
X Sport modes	26
Quick view of page fields	26
Power up mode	26
Realtime mode	27
Race mode	29
Telltale mode	30
Setup mode	34

Setup

Setup mode	37
Entering setup mode	39
The Setup menu structure	41
Menu items not displayed	41
Units menu	44
Alarms menu	44
Beacon menu	45
Club qualifying mode menu	45
RPM menu	46
Wheelspeed menu	47
Gears menu (calculated gear number)	47
Timer menu	48
Options menu	49
Test menu	50
Default menu	50
Reset menu	51
Using Club qualifying mode	52
Enable Club qualifying mode	52
Club qualifying mode operating modes	53
Resetting CQM stored lap data	55
Using a GPS input for speed measurement	56
Introduction	56
End-of-lap marker	57
X Sport up/down timer	59
Timer operating modes	59
Setting a timer	60
Setting up a gear number display	61
Setting up the Gear ratio display	61
Adding a filter to your RPM or wheelspeed signals	64
Setting up the gear number using a gear position sensor	65

At the track

Initial checks	69
Track kit list	69
Checklists	70
A typical day... ..	71
Preparing for an outing	72
Powering up the X Sport	72
Warming up the car	72
Driving the car	73
Alarms	74
Alarm prevention	75
Returning to the pits	76
Inspecting telltales	76
Switching off the car	77

Installation

Fitting the X Sport and sensors	81
Wiring notes	81
Power supply	81
Fitting the X Sport	82
Fitting X Sport on a steering wheel	83
Fitting X Sport in a vehicle dash	84
Wheelspeed measurement	85
RPM measurement	88
Tachometer signals	89
Example X Sport RPM setups	96
Pressure measurement	97
Temperature measurement	99
Optional equipment	101
Beacon receiver	101
Beacon transmitter	103
Sensors and interface boxes	105
ABS sensor interface box	106
Waterspeed sensor	108

	Wheelspeed selector box	110
	Turbo/carburettor pressure sensor	112
	Thermocouple sensor	113
	Fitting a wiring loom	115
	X Sport looms	115
	Connect the loom to the X Sport	116
	Lay the loom in the car	116
	Secure unwanted sensor wires	117
	Connect the sensors	118
	System checks and Power-up	119
	Check the installation	119
	Turn the X Sport on	119
	Set up the X Sport	120
	Connector information	121
	X Sport connector information	121
Troubleshooting		
	X Sport	129
	Engine speed (RPM)	130
	Speed	132
	Lap times (beacon)	135
	Temperatures	137
	Pressures	138
	Telltails	139
Appendices		
	Appendix A - Using the Outing Report Manager	
	(ORM) software	143
	Introduction	143
	Operating system	143
	Software installation	143
	Starting the ORM application for the first time	144
	ORM operating modes	149
	Options	154
	Read only outings	156
	Offload Outings	157

Copy to the clipboard	159
Printing	160
Serial connection	160
Appendix B - Fitting an un-terminated loom	161
Un-terminated loom details	161
Connect the loom to the X Sport	161
Lay the loom in the car	161
Secure unwanted sensor wires	162
Cut the Loom to size	162
Fit SureSeal connectors to the loom	162
Waterproof the SureSeal connectors	165
Repeat the process for each sensor	166
Fit the spade connectors	166
Fit the 4mm ring tags	167
Reinstall the loom	167
Check the installation	167
Appendix C - X Sport ECU loom information	169
X Sport ECU loom connector pinout information	170
Appendix D - X Sport and MBE ECU	173
Introduction	173
External sensors required	173
X Sport setup for use with MBE ECU	173
X Sport display fields used with an MBE ECU	174
X Sport ECU loom	174
Appendix E - X Sport and Pectel T6 2000, T6M and T2 ECUs	175
Introduction	175
Pectel T6 2000 and T6M channels:	175
X Sport setup for use with Pectel ECU	177
X Sport display fields used with a Pectel ECU	177
X Sport ECU loom	177

Appendix F - Using X Sport to display data from a	
Delta logger	179
Introduction	179
Choosing channels to be displayed	179
X Sport setup for use with a Delta logger	180
Appendix G - Using X Sport to send data to a	
Delta logger	181
Introduction	181
Channels available	182
External sensors required	182
X Sport setup for use with a Delta logger	182
X Sport display fields used with a Delta	182
X Sport ECU loom	183
Appendix H - X Sport and Rally P data stream	185
Introduction	185
Rally P channels:	185
X Sport setup for use with Rally P	186
X Sport display fields used with the Rally P	186
X Sport ECU loom	186
Appendix J - X Sport and Interport unit	187
Introduction	187
X Sport setup for use with an Interport unit	187
Menu item changes	187
Interport channels	188
External sensors required	188
X Sport display fields used with an Interport unit	189
Outings Report Manager (ORM)	189
Appendix K - X Sport 7-segment display to text glossary	191
Index	197
Contact information	204

Index

Introduction

This User Guide gives information on the installation and use of the X Sport dash.

If an X Sport has already been fitted to your car, you can get a general idea of the features available within each operating mode (Race mode, Telltale mode, etc.) by looking at the Overview section.

If you are installing an X Sport yourself, you will need to follow the instructions given in the *Installation* section before proceeding.

RPM input

The X Sport requires an RPM (or Tacho) input. Often the Tacho signal from the vehicle ECU can be connected to the RPM input of the X Sport.

Kits C502 and C503 have a Tacho input connection loom (60D-605024) for connecting a Tacho signal to the RPM connector on the X Sport loom. If the Tacho connection is noisy (indicated by an unstable RPM at steady revs) you will need to use a 4-stroke RPM box (part number 01F-152080) to provide the RPM signal. This RPM box has the correct type of connector to plug into the RPM connector on the X Sport loom.

Part numbers

The X Sport is available in a number of Kits, which are listed below.

C501 - X Sport ECU Kit (for use with ECUs)

Part number	Description	Quantity
01D-032405-CGR	X Sport (7-segment LEDs are red, green & blue)	1
OR		
01D-032405-CRR	X Sport (7-segment LEDs are all red)	1
60D-032438	X Sport ECU loom	1
01P-032445	X Sport manual on CD	1

C502 - X Sport Stand Alone Kit

Part number	Description	Quantity
01D-032405-CGR	X Sport (7-segment LEDs are red, green & blue)	1
OR		
01D-032405-CRR	X Sport (7-segment LEDs are all red)	1
29K-071470-1E	X Sport Quick Guide sheet	1
01P-032446	Manuals on CD	1
01G-233020	Temperature Sensor	1
21A-0091	Pressure Sensor (standard, 10 bar)	1
01G-233019	Wheelspeed Sensor (active)	1
60D-605024	Tacho input connection loom	1
X Sport Loom options, choice from:		
31L-0005	X Sport 1 Metre Terminated Loom	1
OR		
31L-0006	X Sport 3 Metre Terminated Loom	1
OR		
31L-0007	X Sport 3 Metre Unterminated Loom	1

C503 - X Sport Outing Report Manager (ORM) Kit

Part number	Description	Quantity
01D-032405-CGR	X Sport (7-segment LEDs are red, green & blue)	1
OR		
01D-032405-CRR	X Sport (7-segment LEDs are all red)	1
02A-00013*	Computer lead	1
01P-032447	Outing Report Manager software and manual on CD	1
29K-071470-1E	X Sport Quick Guide sheet	1
01G-233020	Temperature Sensor	1
21A-0091	Pressure Sensor (standard, 10 bar)	1
01K-162049	10-channel beacon receiver	1
01G-233019	Wheelspeed Sensor (active)	1
60D-605024	Tacho input connection loom	1
X Sport Loom options, choice from:		
31L-0005	X Sport 1 Metre Terminated Loom	1
OR		
31L-0006	X Sport 3 Metre Terminated Loom	1
OR		
31L-0007	X Sport 3 Metre Unterminated Loom	1
with		
13D-032288	Installation kit (for use with 31L-0007)	1

* The Computer lead connects a COM port to the download connector on the X Sport loom. If your PC does not have a serial COM port you can use a Pi Research USB to Serial port adapter, part number 30K-162200.

Declaration Of Conformity

We, the undersigned,

Pi Research
Brookfield Motorsports Centre,
Cottenham,
Cambridgeshire, CB4 8PS
United Kingdom

Certify and declare under our sole responsibility that the following equipment:

Xsport – 032405
A vehicular drivers dash for use in motorsport applications

Conforms to the following EC directives including applicable amendments:

EMC Directive 89/336/EEC, 72/245/EEC (last amended 95/54/EC)

The following standards have been applied:

95/54/EC

Cottenham, 5th February 2004

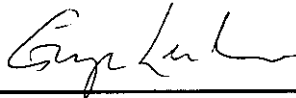

George Lendrum - Director of Motorsport

Conditions Of Use

The X Sport is intended for use in motorsport applications **only** i.e. not on vehicles used on the public road network. For those vehicles that may be used on the public road network e.g. Rally cars, it is the responsibility of the user to verify that the type approval of the vehicle has not been compromised.

Overview

Overview

Introduction

This section gives an overview of the X Sport, its features and modes.

The X Sport is a digital dash which can be used to display data from a number of sensors connected to the dash loom. It can also be used to display data from Pi Systems.

The following options are available:

- Wheel speed sensor
- RPM box
- Temperature sensors
- Pressure sensors
- Installation kit
- Beacon receiver
- Beacon transmitter
- Outings Report Manager kit

The X Sport

The X Sport has a number of display fields which can display the following parameters:

- Speed
- RPM
- Lap times (beacon kit required)
- Oil temperature
- Coolant temperature
- Oil pressure
- Fuel pressure.

The X Sport also has coloured LEDs on the front panel as gear-shift lights that come on in sequence to indicate when a gear change should be made, an RPM redline warning light, a 7-segment LED that displays the page identification letter (or gear number if set up), and an alarm light that lights if the temperature and pressure values exceed preset alarm thresholds.

Telltals

The X Sport will record various maximum and minimum channel values during each lap. These values are the Telltals. The Telltals recorded are listed below:

- Lap number
- Lap time
- Maximum speed
- Minimum speed
- Maximum oil pressure
- Minimum oil pressure
- Minimum fuel pressure
- Maximum coolant temperature
- Minimum coolant temperature
- Maximum RPM
- Minimum battery volts

Alarms

The X Sport will trigger an alarm if thresholds for any of the following parameters are exceeded:

- Maximum coolant temperature
- Maximum oil temperature
- Minimum oil pressure
- Minimum fuel pressure
- Minimum battery voltage

Club qualifying mode

Club qualifying mode (CQM) performs Laptime comparisons. To use CQM you must have a beacon receiver.

Laps are compared by determining when the current distance value equals one of eight distance segments previously stored in the X Sport. At this point the time difference between the current value and stored value is calculated. The difference is shown for the current segment. This is displayed for three seconds before returning to running laptime.

At the end of a lap, the laptime for the lap just completed is shown. If the laptime is faster than the one previously stored in the X Sport and the distance of the two laps are within 5% of each other, the lap just completed is stored and the laptime value is flashed on the X Sport for 10 seconds. If the lap time is slower than the stored lap or the distances are not within 5% of one another then the laptime is static.

At the start of the next lap the process begins again. This continues whilst the X Sport is in **Race Mode**, signified by valid RPM and Speed values.

The beacon receiver

The optional beacon receiver provides the following benefits:

- Fixed lap times or elapsed stage times
- Lap counter
- Lap time telltales
- Qualifying information

The beacon receiver allows an accurate registration of each lap passed. The beacon receiver is an infrared detector which is mounted on the vehicle. An infrared transmitter is placed on the side of the track. As the vehicle passes the transmitter, the infrared signal is picked up by the beacon receiver on the vehicle. The X Sport immediately displays the lap time for the driver.

As well as displaying the time and count for each lap, the beacon enables the X Sport to store and display the maximum and minimum readings for each of the sensors per lap (the Telltales).

Changing the beacon channel number

You can change the channel number set on the 10-channel beacon receiver. The channel numbers are from 0 through to 9, and are changed using a small screwdriver in the slot on the top of the beacon receiver.

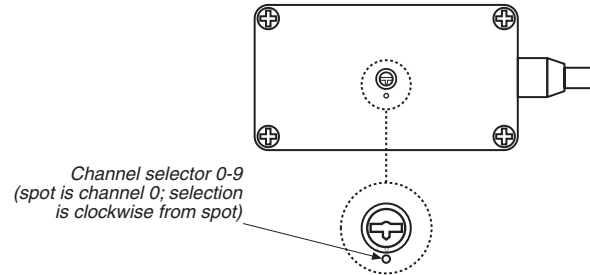

Changing the channel on a 10-channel beacon receiver

Monster beacon transmitter

Most tracks in the UK have a Monster beacon which transmits on Channel 0. To make use of this Monster beacon you must set your beacon receiver to Channel 0.

If you use a track which does not have a Monster beacon installed you will need to use your own beacon transmitter. You can purchase a beacon transmitter from PI Research.

Outings Report Manager software

The optional Outings Report Manager (ORM) software allows you to download the telltales onto a PC. The software then allows you to view an Outing Report of the downloaded telltales.

The ORM also allows you to save, recall and compare previous Outing Reports. You can also copy and paste an Outing Report into a Windows™ Excel spreadsheet or similar application. Refer to Appendix A for information on installing and using the ORM software.

Conventions

Early versions of the X Sport have the RPM Redline warning LED in the centre of the display. Later versions have this Redline warning LED to the right of the display. The later version is shown on the next page.

Display field use

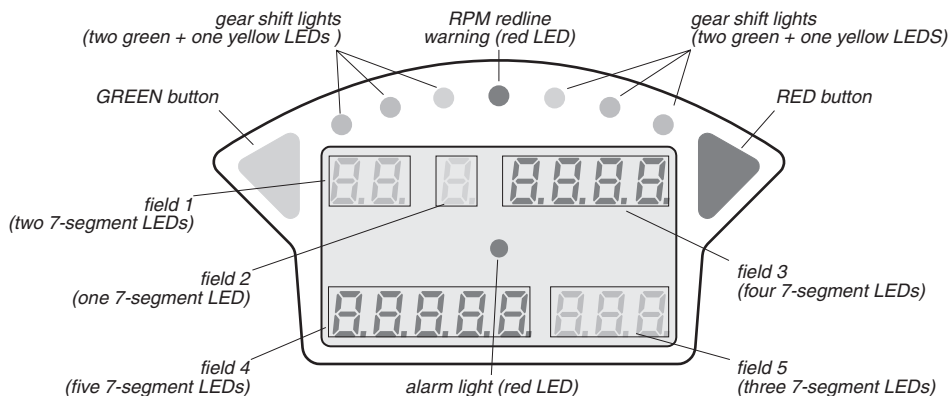

X Sport display fields (early version with centre RPM Redline warning LED)

The following table details what data is shown in the fields on the display pages.

Field	Realtime A	Realtime B	Race	Telltales C	Telltales D	Telltales E
1	W/S sensor	W/S sensor	Lap number	Lap number	Lap number	Lap number
2	Letter A*	Letter B*	Letter r*	Letter C	Letter D	Letter E
3	Oil press	Fuel press**	Speed max***	Max speed	Min oil press	Min fuel press
4	RPM****	Battery volts	Lap time*****	Lap time	Max RPM	Min battery V
5	Cool temp	Oil temp	Speed min latched	Min speed	Max cool temp	Max oil temp

Page options: * Letter is replaced after a 2 seconds delay by gear number if you have set up gear numbers.

** **Fuel press** can be Accelerometer output

*** **Speed max** can be Speed live.

**** **RPM** or **Up** or **Down** count if timer is set.

***** **Lap time** if a beacon is enabled, **RPM** if not, or Timer information. Flashes Lap time at the end of a lap, then reverts to timer information.

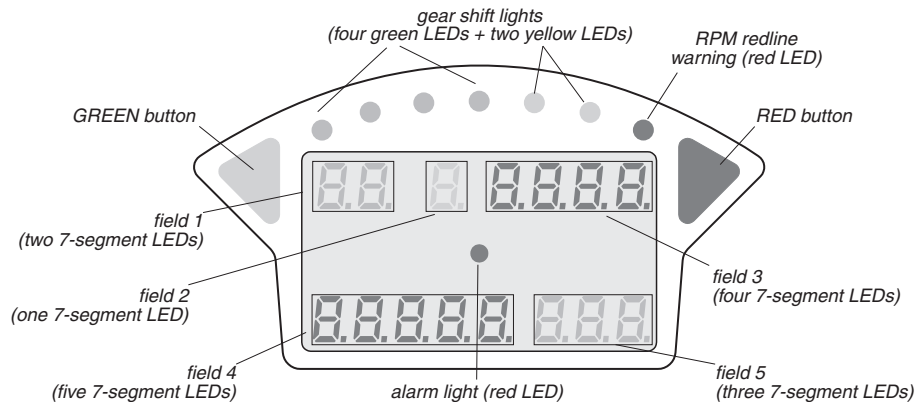

X Sport display fields (later version with RPM Redline warning LED at right)

The following table details what data is shown in the fields on the display pages.

Field	Realttime A	Realttime B	Race	Telltales C	Telltales D	Telltales E
1	W/S sensor	W/S sensor	Lap number	Lap number	Lap number	Lap number
2	Letter A*	Letter B*	Letter r*	Letter C	Letter D	Letter E
3	Oil press	Fuel press**	Speed max***	Max speed	Min oil press	Min fuel press
4	RPM****	Battery volts	Lap time*****	Lap time	Max RPM	Min battery V
5	Cool temp	Oil temp	Speed min latched	Min speed	Max cool temp	Max oil temp

Page options: * Letter is replaced after a 2 seconds delay by gear number if you have set up gear numbers.



** **Fuel press** can be Accelerometer output

*** **Speed max** can be Speed live.

**** **RPM** or **Up** or **Down** count if timer is set.

***** **Lap time** if a beacon is enabled, **RPM** if not, or Timer information. Flashes Lap time at the end of a lap, then reverts to timer information.

Button functions

BUTTON PRESS	TIME (seconds)	EXAMPLE
Click		Click GREEN button to cycle through Pages in Real-time mode
Press and Hold		Press and Hold both RED and GREEN buttons to enter or exit Setup mode
Press and Hold		To show the information which will be displayed in each field on a selected Page, Press and Hold the GREEN button

X Sport modes

The X Sport automatically switches into one of four different operating modes depending on whether the vehicle is stationary, is being driven, or has just returned from an outing. These operating modes are:

- Power up mode
- Realtime mode
- Race mode
- Telltale mode.

In addition to the four normal operating modes, a Setup mode exists for you to adjust alarm thresholds (e.g. for low oil pressure or high oil temperature), the RPM Redline setting and other parameters.

The word Page is used to describe a single screen display on the X Sport. Each Page is identified by a letter displayed in the page ident field (display field 2).

Quick view of page fields

To quickly view the settings for each page you use the GREEN button on the X Sport:

- Press and hold the GREEN button to show the fields used on a page.
- Click the GREEN button to switch between the pages.

Power up mode

When power is first switched on, the X Sport performs a selftest check of the display. After the selftest has finished, information on the version of the software installed in the X Sport is shown display field 3 for three seconds.

You should make a note of the software version number and have it ready if you ever need technical support.

Realtime mode

After power has been applied, and the selftest has completed successfully, the X Sport goes into Realtime Page A and remains there until the vehicle is driven (or until Realtime Page B has been selected). As the name suggests, Realtime mode is used to show the readings of the sensors on the vehicle in real time (i.e. continuously), as they happen.

The display fields are also used to show some options after the options have been set up. e.g. If a timer has been setup (Up timer or Down timer) the RPM field on Realtime Page A displays the timer information instead of the RPM information.

Realtime Page A

Parameter	Field	Comment
Speed	1	Shows the output from the wheelspeed sensor.
Letter A	2	
Oil pressure	3	
RPM	4	Timer information if a timer has been set up
Coolant Temperature	5	

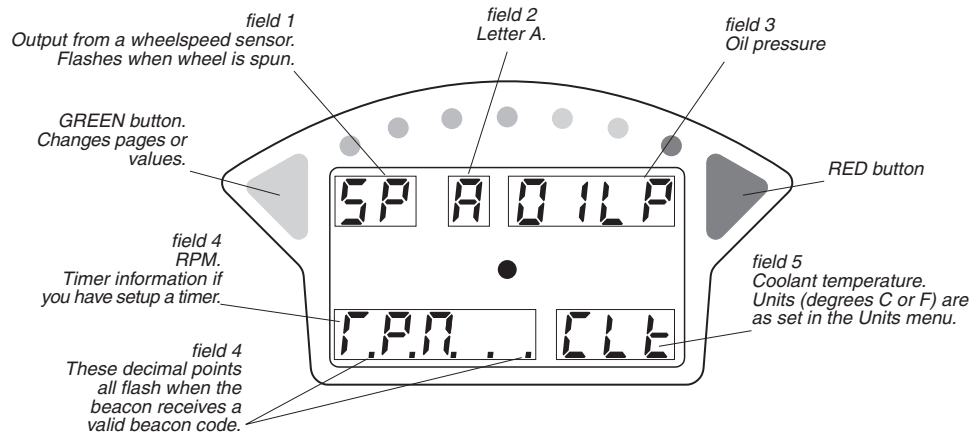

Realtime Page A

Realtime Page B

Parameter	Field	Comment
Speed	1	Shows the output from the wheelspeed sensor.
Letter b	2	
Fuel pressure (or gear)	3	Gear number if gear number using a gear position sensor has been set up.
Battery volts	4	
Oil Temperature	5	

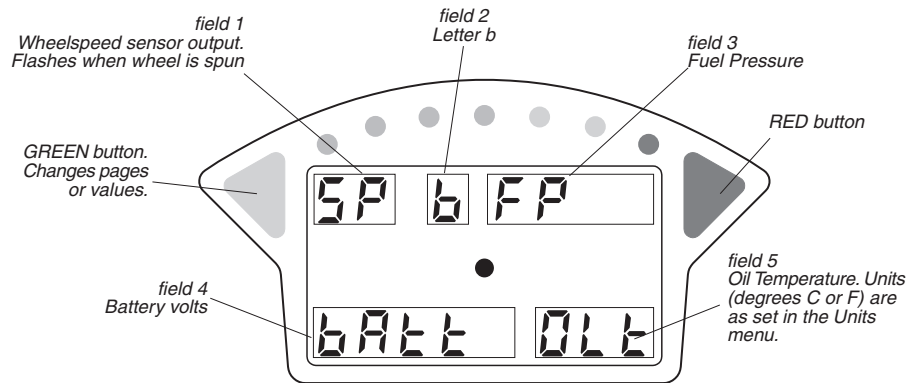

Realtime Page B

Race mode

The X Sport enters Race mode when the vehicle exceeds its minimum Out speed, for example 40 m.p.h., and it automatically switches to Race page (Page r). Latched maximum speed can be displayed instead of Realtime speed by selecting the Latched option in Setup. If the gear number option has been set, the letter r in the page ident field is replaced by the gear number after a 2 seconds delay. Laptime is shown if you have a beacon set up, otherwise the field displays RPM.

Race page

Parameter	Field	Option
Lap number	1	
Letter r	2	Gear number if you have set up gears
Realtime speed	3	Latched maximum speed
Laptime	4	RPM. Or if a timer has been enabled it shows timer information. It flashes the laptime at the end of each lap, then reverts to timer information.
Latched minimum speed	5	

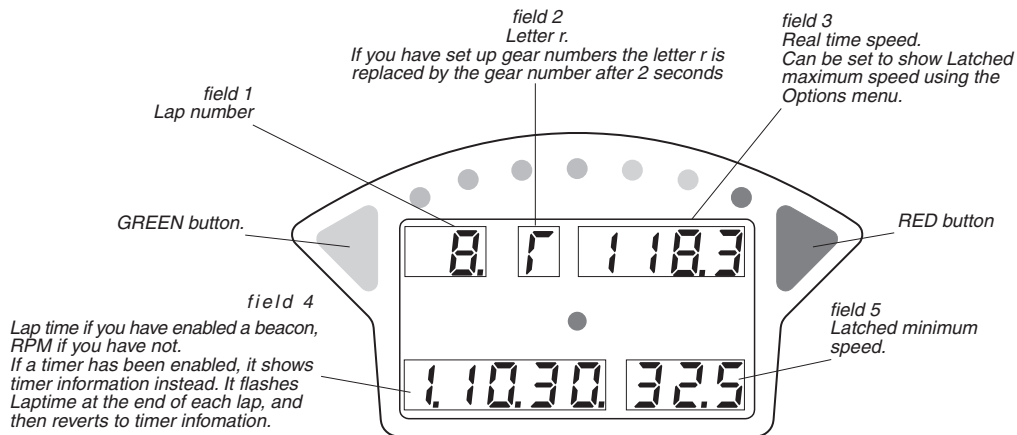

Race page

Telltale mode

When you return to the pits after driving the vehicle around the track and you have stopped and turned the engine off, the X Sport switches to Telltale mode to show you important information about the outing you've just completed. When the outing has stopped all the RPM lights simultaneously flash if there is Telltales data stored in the X Sport. The X Sport also transmits the data in bursts on the download connector every ten seconds.

If you have the ORM software application you can download the Telltales data to a PC and analyse them at a later date.

CAUTION: If you remove power from the X Sport, ALL Telltale data will be lost.

In Telltale mode, three Telltale Pages display the following information. You can scroll through the telltales lap by lap, by clicking the RED button whilst on a Page.

Telltale page C

Parameter	Field
Lap number	1
Letter C	2
Maximum speed	3
Lap time	4
Minimum speed	5

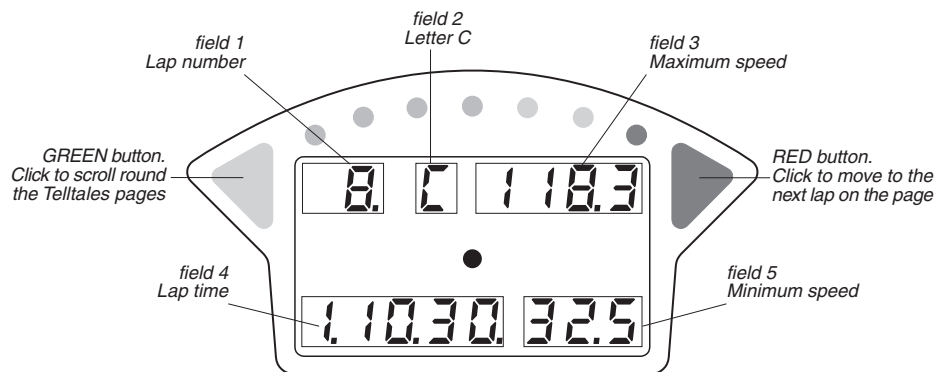

Telltale page C

Telltale page D

Parameter	Field
Lap number	1
Letter d	2
Minimum oil pressure	3
Maximum RPM	4
Maximum coolant temperature	5

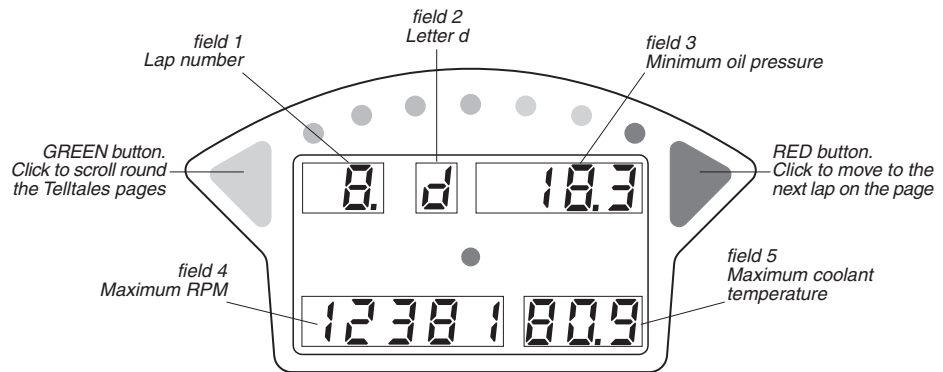

Telltale page D

Telltale page E

Parameter	Field	Option
Lap number	1	
Letter E	2	
Minimum fuel pressure	3	Shows a bar if you have gear number set up
Minimum battery volts	4	
Maximum oil temperature	5	

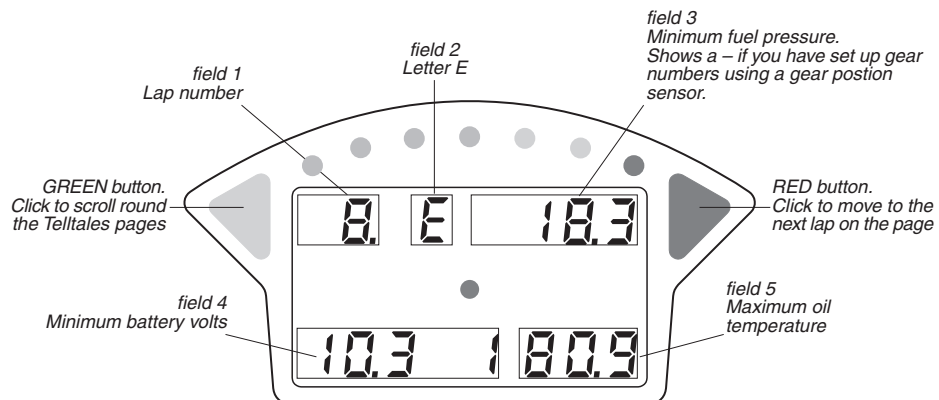

Telltale page E

Setup mode

The X Sport is preprogrammed with default settings, but it may be necessary to alter these values to suit your vehicle.

Some of these parameters only need to be set once when the X Sport is installed. However, you may wish to adjust parameters such as the oil pressure or the battery voltage alarm level more frequently.

Details of how to setup the X Sport are given in the *Setup* section of this User Guide, together with a list of the parameters you change.

Setup

Setup mode

This section describes in detail how to setup the X Sport. You will need to do this when you first install an X Sport.







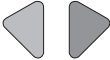

To allow the X Sport to be used on a wide range of vehicles, there are a number of parameters that can be adjusted to your particular requirements.

Some of these parameters only need to be set once, when X Sport is installed. However, you may wish to adjust parameters such as the RPM overrev light more frequently.

The table below shows how Parameter values are organised in Setup groups. The table on the next page summarises the X Sport button operations for editing parameter values in Setup mode.

<i>Setup groups</i>	<i>Parameter values</i>
UNITS	Speed / Temperature / Oil Pressure
ALARMS	Oil Temp. / Coolant Temp. / Oil Pressure / Battery
BEACON	Beacon Fitted / Mode / Mask
CQM	Enabled / Reset
RPM	Redline / Redline Start / Launch / Launch Start / Pulses
WHEELSPEED	Tyre Diameter / Triggers / Outing Speed
GEARS	Enable / Type / Filter / Number Of Gears
TIMER	Enabled / Type / Time
OPTIONS	ORM / Brightness / Unit Number / Speed / Type / Gears / GPS / GPS Zone / Accelerometer
TEST	piXpress use only. DO NOT USE.
DEFAULT	Reset ALL fields to default settings

Note: Repeat the steps for setting parameter values as often as necessary before saving the current settings.

<i>To do this:</i>		<i>Do this:</i>
<i>Enter Setup mode:</i>		<i>Press and Hold GREEN and RED buttons together</i>
<i>Step through Setup groups:</i>		<i>Click RED button</i>
<i>Inspect or alter a Setup group:</i>		<i>Press and Hold RED button</i>
<i>Step through Parameter values:</i>		<i>Click RED button</i>
<i>Increment values:</i>		<i>Click GREEN button</i>
<i>Auto-adjust values:</i>		<i>Press and Hold GREEN button</i>
<i>Save the current settings within each Setup group:</i>		<i>Press and Hold RED button</i>
<i>Save all current settings:</i>		<i>Press and Hold GREEN and RED buttons together</i>

Entering setup mode

The vehicle must be powered up, stationary and the dash set to Realtime mode. You cannot access Setup mode from Race mode.

- 1 Press and hold the RED and GREEN buttons together for two seconds.

After approximately 2 seconds the screen display will change to read $\overline{S} \overline{E} \overline{t} \overline{U} \overline{P}$ (Setup). Release the buttons and the first main menu will be displayed.

*Note: If you have previously set the **Options >Type** to **DELTA**, the X Sport will not enter Setup mode by pressing and holding the RED and GREEN buttons together. You **MUST** power cycle the X Sport whilst pressing and holding both buttons to force the X Sport into Setup mode.*

Selecting a group

- 1 Click the RED button to cycle through the groups.

Stop on the one you want to view or change.

- 2 Press and hold the RED button.

Selecting a Parameter

- 1 Click the RED button to cycle through the parameters until you reach the one required.

You can either Alter or Inspect a parameter.

Altering a parameter

There are two ways to alter the value of a parameter once you have selected it: Step mode and Auto-adjust mode.

Step mode

Step mode is most suited to values that have a small range, or only switch from Yes to No.

- 1 Click the GREEN button to increment the value of a parameter one step at a time.

Auto-adjust mode

This mode is most suited to parameters that have a wide range of values, such as temperatures or tyre diameter.

- 1 First Press and hold the GREEN button.

If auto-adjust is available for a parameter, the digits will start to flash between 0 and 9.

- 2 Release the GREEN button. The digits flash between 0 and 9.
- 3 Click the GREEN button to freeze each digit at its correct value, starting with the left-most digit.

Once all the digits have been frozen, auto-adjust mode ends automatically.

Note: If you make a mistake, click the RED button until the parameter reappears, and then start adjusting the value again.

To Inspect or Alter other parameters in the Group

- 1 Click the RED button.

To Return to the Setup Groups

- 1 Press and hold the RED button to return to the Setup Groups.

You can then select another Group of parameters or leave Setup mode.

To leave Setup mode

To save the parameters and exit from Setup mode:

- 1 Press and hold the RED button to return to the main Setup Groups.
- 2 Press and hold the RED and GREEN buttons for two seconds to return to page A.

To Exit without saving changes

If you make a mistake or change your mind, you can restore the previously stored settings by switching off the dash (e.g. with the master switch) before exiting Setup mode.

The Setup menu structure

The configuration menus in the X Sport is made up of two levels, a Main menu and a Sub menu. In the following tables the first option displayed is the default setting. For example, Speed uses MPH as its default.

*Note: If you have previously set the **Options >Type** to **DELTA**, the X Sport will not enter Setup mode by pressing and holding the RED and GREEN buttons together. You **MUST** power cycle the X Sport whilst pressing and holding both buttons to force the X Sport into Setup mode.*

Menu items not displayed

Some items within the menu structures are not displayed when the X Sport is in certain operating modes.

The next table details these items and modes.

Main menu	Sub menu	Comments
Units		Not shown in DELTA or INTERPORT modes
	SPEED	Not shown in DELTA or INTERPORT modes
	TEMP	Not shown in DELTA or INTERPORT modes
	FUELPRS	Not shown in DELTA or INTERPORT modes or if ACCELEROMETER is set to YES
	OILPRSS	Not shown in DELTA or INTERPORT modes
Alarms		Not shown in DELTA mode
	OILTEMP	Not shown in DELTA mode
	COOLTMP	Not shown in DELTA mode
	OILPRSS	Not shown in DELTA mode
	FUELPRS	Not shown in DELTA mode or if ACCELEROMETER is set to YES
	BATTERY	Not shown in DELTA mode

table continued on the next page

Main menu	Sub menu	Comments
Beacon		Not shown in DELTA mode
	FITTED	Not shown in DELTA mode
	MODE	Not shown in DELTA mode
	MASK	Not shown in DELTA mode
CQM		Not shown in DELTA mode
	ENABLED	Not shown in DELTA mode
	RESET	Not shown in DELTA mode
RPM		
	REDLINE	Not shown in DELTA mode
	RDLN ST	Not shown in DELTA mode
	LAUNCH	Not shown in DELTA mode
	LNCH ST	Not shown in DELTA mode
	PULSES	Not shown in DELTA, MBE, PECTEL, OBDII, RALLY, or INTERPORT modes
Wheelspeed		Not shown in DELTA mode
	DIAMETR	Not shown in DELTA, OBDII, INTERPORT, GPS modes
	TRIGGER	Not shown in DELTA, OBDII, INTERPORT, GPS modes
	OUTSPD	Not shown in DELTA mode
Gears		Not shown in DELTA mode
	ENABLED	Not shown in DELTA mode
	TYPE	Not shown in DELTA mode
	FILTER	Not shown in DELTA mode
	NO.GRS	Not shown in DELTA mode
Timer		Not shown in DELTA mode
	ENABLED	Not shown in DELTA mode
	TYPE	Not shown in DELTA mode
	TIME	Not shown in DELTA mode

table continued on the next page

Main menu	Sub menu	Comments
Options		Always shown
	ORM	Always shown, default is NO. disables ORM output stream
	BRIGHT	Always shown
	UNIT NO	Always shown
	SPEED	Always shown
	TYPE	Always shown
	GEARS	Not shown if AUTO GEARS is enabled
	GPS	Not shown in DELTA, MBE, PECTEL modes
	GPS ZONE	Only shown when GPS is enabled or when INTERPORT mode is selected
Test		Always shown
	DEMO	Always shown
	SELFST	Always shown

Units menu

Main menu	Sub menu	Options	Comment
UNITS (Units)	SPEED (Speed)	MPH (MPH)	
		KPH (KPH)	
	TEMP (Temperature)	C (Centigrade)	
		F (Fahrenheit)	
	FUELPRES (Fuel pressure)	PSI (PSI)	
		KGF (KGF)	
		BAR (BAR)	
		TBAR (TBAR)	
	OILPRESS (Oil pressure*)	PSI (PSI)	Can be Boost pressure*
		KGF (KGF)	
		BAR (BAR)	
		TBAR (TBAR)	

*Oil pressure changes to Boost pressure when the X Sport **Type** is set to OBDII.

Alarms menu

Main menu	Sub menu	Range	Comments
ALARMS (Alarms)	OILTEMP (Oil temperature)	0 to 999	C or F (Set in Units menu)
	COOLTEMP (Coolant temperature)	0 to 999	C or F (Set in Units menu)
	OILPRESS (Oil pressure)	0 to 999	PSI (Set in Units menu)
		0.00 to 9.99	BAR (Set in Units menu)
	FUELPRES (Fuel pressure*)	0 to 999	PSI (Set in Units menu)
		0.00 to 9.99	BAR (Set in Units menu)
BATT EGY (Battery)	7.0 to 20.0	Volts	

The current setting for the alarms will be displayed after the alarm name as you scroll through the menu.

Beacon menu

Main menu	Sub menu	Options	Range	Comments
<i>bEACON</i> (Beacon)	<i>FITTED</i> (Fitted)	<i>NO</i> (No)	-	No lap time displayed
		<i>YES</i> (Yes)	-	Lap time displayed
	<i>MODE</i> (Mode)	<i>RUN</i> (Run)	-	Running lap time (freezes for 5 seconds at end of a lap)
		<i>FIX</i> (Fix)	-	End of lap time
<i>MASK</i> (Mask)			0 to 99	In seconds. Sets the beacon mask time*

*The beacon mask time function disables the beacon receiver input on the X Sport for the set number of seconds after an end-of-lap beacon is seen. This prevents a second beacon being picked up by the X Sport if there is another Pi Research beacon transmitter on the start/finish straight.

Club qualifying mode menu

Main menu	Sub menu	Setting	Range	Comments
<i>CQM</i> (CQM)	<i>ENABLED</i> (Enabled)	<i>YES</i> (Yes)	-	
		<i>NO</i> (No)	-	
	<i>RESET</i> (Reset)	<i>DONE</i> (Done)	-	

RPM menu

Use these options to set Redline value (or Overrev) and the number of ignition pulses. Instructions on setting up the RPM measurement are included in the *Installation* section.

Main menu	Sub menu	Setting	Range	Comments
RPM (RPM)	REDLINE (Redline)	6500	0 to 99999	See Note 1 below
	REDLINE START (Redline start)	5900	0 to 99999	See Note 2 below
	LAUNCH (Launch)	6500	0 to 99999	See Note 3 below
	LAUNCH START (Launch start)	5900	0 to 99999	See Note 4 below
	PULSES (Pulses)	4	1 to 16	See Note 5 below

Note 1. Redline. This sets the RPM value at which the Redline alarm LED on the X Sport triggers. The engine must be running and the Outing Speed exceeded. When the Redline setting has been exceeded, the Redline alarm LED and all the Gear shift light LEDs all flash.

Note 2. Redline start. This sets the RPM value at which the first Gear shift light illuminates. The X Sport then automatically works out at what RPM values the other Gear shift lights will illuminate.

Redline start example. If the Redline value is set to 6500 RPM, and the Redline start value is set to 5900, the first Gear shift lights illuminate at 5900 RPM, the second at 6100 RPM, the third at 6300 RPM, and the Redline alarm LED will illuminate at 6500 RPM. At 6501 RPM the Redline alarm light and ALL the Gear shift lights will flash.

Note 3. Launch. Sets the RPM value at which the Redline alarm light on the X Sport triggers when the engine is running but the vehicle is stationary. e.g. the vehicle is on the start line waiting for the signal to start racing. Once moving, the X Sport sees a wheel speed signal and uses the standard Redline setting.

Note 4. Launch start. This sets the RPM value at which the first Gear shift light illuminates. The X Sport then automatically works out at which RPM values the other Gear shift lights will illuminate.

Note 5. Pulses. Pulses refers to the number of ignition pulses per TWO revolutions of the engine.

Wheelspeed menu

Main menu	Sub menu	Setting	Range	Comments
WHEELSP (Wheelspeed)	DIAMETER (Diameter)*	535	1 to 999	measured in mm
	TRIGGERS (Triggers)	2	1 to 100	
	OUTSPD (Outing start speed)	20	0,2,20,40,80,112	

**Note: Take special care in measuring the tyre diameter since this setting affects the accuracy of all speed readings.*

Gears menu (calculated gear number)

This menu allows you to set up Gear ratio numbers without using a gear position sensor (potentiometer). If you use this menu, the X Sport uses information from the RPM and Wheelspeed signal inputs to calculate a gear ratio number.

Main menu	Sub menu	Setting	Range	Comments
GEARS (Gears)	ENABLED (Enabled)	NO (No)		
		YES (Yes)		
	TYPE (Type)	AUTO (Auto)		
		USER (User)		
		FILTER (Filter)*		1 to 5
	NO. GRS (Number of gears)		1 to 8	

*Filter. If your wheelspeed signal is noisy it may cause the gear number display to be unstable. The lowest or weakest filter is 1, and 5 is the highest or strongest filter. The stronger the filter, the more accurate the RPM and speed values will be, but the X Sport will take longer to change the ratio display.

Timer menu

Main menu	Sub menu	Setting	Range	Comments
T I M E R (Timer)	EN A B L E D (Enabled)	n o (No) y e s (Yes)		
	T Y P E (Type)	u p (Up) d n (Down)		
	T I M E (Time)	60	0-99	In minutes

Options menu

Main menu	Sub menu	Setting	Range	Comments
<i>OPTIONS</i> (Options)	<i>ORM</i> (ORM)	No	No/Yes	disables ORM output stream
	<i>BRIGHT</i> (Bright)	0.20	0.05–1.00	Dash LED brightness
	<i>UNITNO</i> (Unit no)	1	1 to 999	Identifies the X Sport for ORM.
	<i>SPEED</i> (Speed)	<i>LATCH</i> (Latch)		Max/Min display.
		<i>REAL</i> (Real)		Real time values.
	<i>TYPE</i> (Type)	<i>SA</i> (SA)		Stand Alone X Sport.
		<i>MBE</i> (MBE)		Displays MBE ECU data
		<i>PECTEL</i> (Pectel)		Displays Pectel ECU data
		<i>RALP</i> (RAL P)		Displays Ford Rally data
		<i>DELTA</i> (Delta)		Displays data from a Pi Delta logger.
		<i>ObdII</i> (OBDII)		Displays data from a Pi OBDII interface unit
		<i>INTERP</i> (Interport)		Displays data from a Pi Interport unit
	<i>GEARS</i> (Gears)	<i>NO</i> (No)		
		<i>YES</i> (Yes)	2-8	See Note 1 below.
		Sensor value		Values from the potentiometer.
	<i>GPS</i> (GPS)	<i>YES</i> (Yes)		GPS can be used to provide speed.
		<i>NO</i> (No)		
	<i>GPS ZONE</i> (GPS zone)	100	000 to 999	
	<i>ACCELO</i> (Accelerometer)	<i>NO</i> (No)	No/Yes	
		<i>YES</i> (Yes)		See Note 2 below.

Note 1. This option allows you to set up a gear number display using a potentiometer connected to the Fuel pressure input channel.

Note 2. This option allows you to use an accelerometer connected to the Fuel pressure input channel.

Test menu

CAUTION: Under the Test menu there is an option to Selftest the X Sport. This option is for piXpress use only. Any attempts made to run this feature will result in the X Sport displaying a fail message.

Main menu	Sub menu	Setting	Comments
TEST (Test)	DEMO (Demo)	OFF (Off)	Normal use
		FIX (Fix)	Allows a photograph to be taken
	SELFTST (Selftest)	OFF (Off)	A running demonstration piXpress use only

Default menu

Main menu	Sub menu	Comments
DEFAULT (Default)		Press and hold the Red button for 3 seconds, and then release the button. CONFIRM appears.
	CONFIRM (Confirm)	Press and hold the Green button for 3 seconds, then release the button, to set all parameters to their default settings.

After the GREEN button has been held for 3 seconds the display reverts to

DEFAULT and the following message scrolls across display field 4:

RESETTING TO DEFAULTS (Resetting to defaults).

After the message has finished the UNITS (Units Main menu) appears.

Reset menu

The Reset menu is separate to Setup mode and enables you to reset some commonly used parameters that you may need to change frequently.

You can reset the following parameters:

- Club qualifying mode time if CQM is enabled
- Lap number
- Accelerometer output
- Timer start if a Count up or Count Down timer has been enabled
- GPS lap number if GPS is enabled
- OBDII protocols scan if OBDII mode has been enabled
- Gear number is recalibrated if Calculated gear number position has been enabled.

Using the Reset menu

1 Press and hold the RED button for 2 seconds.

If this is the first reset you have performed after powering up the X Sport, and you also have set up a beacon, the X Sport will display the Lap Number reset page. After the first reset, the X Sport remembers the last reset that you did, and this is the reset page that will be displayed until power has been removed from the X Sport.

2 If this is the parameter you want to reset press the GREEN button to reset the parameter.

OR If this is not the parameter scroll through the menu by clicking the RED button until you find the parameter that you want to reset.

3 Press the GREEN button to reset the parameter.

Note: If you select a setting but do not press the GREEN button, the X Sport will automatically exit from the Reset menu.

Using Club qualifying mode

To use Club qualifying mode (CQM) the beacon must be turned on and configured correctly and Club qualifying mode must be enabled on the X Sport.

Enable Club qualifying mode

To use Club qualifying mode it must be enabled in the X Sport.

To enable (or disable) Club qualifying mode:

- 1 Press and hold both the RED and GREEN buttons to enter **SETUP** mode.
- 2 Click the RED button until **CQM** appears.
- 3 Press and hold the RED button. Enabled appears in the top display field.
- 4 Click the GREEN button to change between **no** and **yes** as required.

Yes enables Club qualifying mode, no disables Club qualifying mode.

- 5 Click the RED and GREEN buttons to return to the Realtime page A.

Club qualifying mode operating modes

Club qualifying mode has two modes, Learn **mode** and **Operating mode** .

Learn mode

Learn mode is initiated when the X Sport has no stored lap data. This occurs with either a new X Sport or when the stored lap data has been reset.

Learn mode takes the form of three separate stages which are shown on the X Sport Laptimer display field.

The running Laptimer and the words **LRN 1**, or **LRN 2** or **LRN 3** are alternately shown on the X Sport.

Word	Meaning
LRN 1	The X Sport is looking for the first beacon trigger used for synchronisation
LRN 2	The X Sport is now synchronised and is looking for another beacon to measure the lap distance.
LRN 3	The X Sport now has a stored lap of distance only. This lap has been split into eight equal distance segments and is collecting time stamps for each of the eight segments

At the end of stage **LRN 3** the distance of that lap is compared to the distance of the lap stored in **LRN 2** .If the distances are within 5% of each other, the lap of **LRN 3** is stored into non volatile storage area in the X Sport and can then be used for normal CQM operation.

Operating mode

Once a lap has been learned the X Sport can be used in Operating mode.

Operating mode needs to be synchronised before it will determine Qualifying Times. This is automatic when in Learn mode and as soon as learning is complete the X Sport is already synchronised and laptime comparison begins.

After power up the X Sport needs to synchronise itself by looking for the first end of lap beacon. Until this beacon is seen, the X Sport alternates between showing the running laptime and **SYNC**.

Once synchronised, the X Sport begins a laptime comparison. The lap is compared by determining when the current distance value equals one of the eight distance segments stored in the X Sport. At this point the time difference between the current value and the stored value is calculated. The difference in the form **+/-x.xx.xx** is shown for the current segment. This is displayed for three seconds before returning to running laptime.

At the end of the lap, the laptime for the lap just completed is shown. If the laptime is faster than the one stored in the X Sport and the distance of the two laps are within 5% of one another then the lap just completed is stored and the laptime value is flashed on the X Sport for 10 seconds as per normal. If the lap time is slower than the stored lap or the distances are not within 5% of one another then the laptime is shown static and does not flash.

At the start of the next lap the process begins again. This continues whilst the X Sport is in **Race Mode** signified by a valid RPM and Speed values.

Resetting CQM stored lap data

Resetting the stored lap data can be achieved in one of two methods.

To reset the stored lap data using the first method:

- 1 Press and hold both the RED and GREEN buttons to enter **SETUP** mode.
- 2 Click the RED button until **CQM** appears.
- 3 Press and hold the RED button to enter the **CQM** menu.
- 4 Click the RED button until **RESET** appears.

The stored lap time is shown on the bottom field of the display.

- 5 Press and hold the GREEN button until **DONE** is shown.

OR

To reset the stored lap data using second method:

- 1 In a non setup page, press and hold the GREEN button for 2 seconds. The lower left display field will show **RESET**.
- 2 Continue holding the button for another 2 seconds. The display will show **DONE**. The stored lap data has now been reset.

CAUTION: Releasing the button before 'DONE' is displayed will NOT reset the stored data.

Using a GPS input for speed measurement

Introduction

A GPS system can be used to provide the X Sport with a Speed input. The GPS input can also be used to provide an end-of-lap (EOL) marker.

To use the GPS functions, the X Sport must have an NMEA0183 compatible GPS system running RS232 input at 4800 baud rate connected to the ECU input on the Loom.

To enable the GPS functions:

- 1 Press and hold both the RED and GREEN buttons to enter **SETUP** mode.
- 2 Click the RED button until **Options** appears.
- 3 Press and hold the RED button until **Bright** appears.
- 4 Click the RED button until **GPS** appears.
- 5 Click the GREEN button to change between **no** and **yes** as required.

Yes enables GPS functions, no disables GPS functions.

- 6 Press and hold both the RED and GREEN buttons to return to the Realtime page A.

Once enabled and with a suitable GPS system connected, Speed will automatically be derived from the GPS data stream.

End-of-lap marker

It is possible to use the GPS positioning information to 'mark' and check an end-of-lap (EOL) position as though it were an end-of-lap beacon. This EOL marker is then used by the X Sport for Lap timing and Lap number calculations.

Storing an EOL marker position

Whilst moving with the GPS function enabled, the X Sport is constantly updating its current position information. To store an EOL marker position the driver must choose a suitable point on the track bearing in mind the following factors:

- A straight just after a corner would give most accurate results due to lower speed at time of position checking;
- The end of a long high speed straight would give less accurate results due to the 1Hz update of the GPS data stream;
- Try to choose a piece of track away from other parts of the track travelling in the same direction which may give inaccurate results;
- It should work anywhere but certain positions are likely to give more accurate lap timing.

When a suitable position has been chosen the driver must select the **GPS LAP >RESET** parameter from the Reset menu, by pressing and holding the RED button. (The X Sport remembers the last Reset that was done, so if **GPS LAP RESET** is not displayed, click the RED button until it is.) Press the GREEN button to store the current position as the EOL marker.

The EOL marker is stored in non-volatile memory and will be retained during a power cycle, therefore it will only need to be learnt once each time you visit a track.

GPS zone

The EOL marker works on the principle of storing a lat/long position. Whilst the car is moving, the X Sport is constantly working out the distance from the stored position. When getting closer to the stored position the X Sport is looking for the distance from the EOL marker to be within a 'zone'.

For Setup/testing purposes the parameter **GPS ZONE** is configured from the Options menu and will only be available if GPS has been enabled.

To set the GPS ZONE value:

- 1 Press and hold both the RED and GREEN buttons to enter Setup mode.
- 2 Click the RED button until **Options** appears.
- 3 Press and hold the RED button until **Bright** appears.
- 4 Click the RED button until **GPS ZONE** appears.
- 5 Click the GREEN button to change the **GPS ZONE** value.

The GPS zone value represents a zone of xxx metres around the EOL marker position.

- 6 Press and hold both the RED and GREEN buttons to return to the Realtime page A.

Once enabled and with a suitable GPS system connected, Speed will automatically be derived from the GPS data stream. The X Sport will look for the nearest position to the EOL marker position stored value before declaring this as a valid beacon position. This will trigger the EOL and increment the Lap number and reset the Lap time.

Another EOL will not be triggered until the position has left and re-entered the GPS zone around the EOL position, this ensures only one beacon per lap is achieved.

The **Beacon mask** setting and **Lap Time** display work in the same manner as using a traditional beacon receiver.

X Sport up/down timer

The X Sport has a timer function, which can be set to count down or count up. The timer value can only be seen when the X Sport is on Realtime Page A or in Race mode.

Realtime Page A

On Realtime Page A the timer information is shown in the RPM display field instead of the RPM information.

Race mode

In Race mode the timer information is shown in the Lap time display field. At the end of a lap the timer information is replaced for ten seconds with Lap time information. The timer continues to run when this happens so that when the display changes back to timer it shows the current state of the timer.

Timer operating modes

The timer has two modes of operation:

- Up timer
- Down timer

Up timer

In Up timer mode the display field is replaced with an incrementing timer value that starts at 0 and increments whilst the X Sport is powered or you reset the timer. The timer resolution is hours:minutes:seconds. Once started, the timer increments in whole seconds.

Down timer

In Down timer mode the display field is replaced with a decrementing timer value that counts down from the set time and stops at 0. The timer resolution is hours:minutes:seconds. Once started, the timer decrements in whole seconds only. At one minute to go before 0 is reached, the display flashes the time. The display continues to flash when the timer reaches 0.

Setting a timer

To use the timer functions, the timer must be enabled in the **Setup** menu.

To use the timer functions:

- 1 Press and hold both the RED and GREEN buttons to enter **Setup** mode.
- 2 Click the RED button until **timer** appears.
- 3 Press and hold the RED button until **enabled** appears.
- 4 Click the GREEN button to change from **no** to **yes**.
- 5 Click the RED button to show **type**.
- 6 Click the GREEN button to change the type (**dn** or **up**) as required.
- 7 Click the RED button to show **time**.
- 8 Press and hold the GREEN button. This is an auto-adjust field and the digits will start to flash between 99 and 00. This is **time** in whole minutes.
- 9 Click the GREEN button to freeze each digit at its required value, starting with the left-most digit.

Once both of the digits have been frozen auto-adjust mode ends automatically.

- 10 Press and hold both the RED and GREEN buttons until Realtime page A appears.

You must now start the timer running.

- 11 Press and hold the RED button. The Reset menu appears.

(The X Sport remembers the last Reset that was done, so if **Timer Start** is not displayed, click the RED button until it is.)

- 12 Press the GREEN button to start the timer. The X Sport starts the timer and the display returns to Realtime Page A.

Once started the timer will change in whole seconds only.

Setting up a gear number display

The X Sport can display gear numbers. You have three ways of setting the X Sport to display gear numbers:

- Using RPM and Speed signal inputs to automatically determine gear ratios
- Using RPM and Speed signals and manually telling the X Sport when a gear ratio has been found
- Using a gear position sensor (potentiometer) connected to the Fuel pressure channel.

Setting up the Gear ratio display

The X Sport can be set up to display what gear ratio you are in. This is a quick and easy way of displaying a gear number without having to add extra sensors to your vehicle. The X Sport can do this automatically (**Auto**) or manually (**User**).

Automatic ratio selection

The X Sport can auto-detect the number of ratios that you have specified in the Gears menu using information from the RPM and Wheelspeed signal inputs. You do not need to cycle through the gears in order, as the X Sport will sort the ratios when it has detected them all. When the X Sport is in this mode, the gear number displayed is showing the number of separate ratios that the X Sport has detected. When it has detected all the ratios, it will sort them and then start displaying them automatically.

Setting up the Auto ratio selection feature:

If this is the first time that you have set up the gear display, you will need to enable all of the features before setting it up; follow the steps below. If you have previously enabled the gear display feature, go straight to step **11**.

- 1** Press and hold both RED and GREEN buttons until **Setup** is displayed.
- 2** Click the RED button to scroll through the menus until you come to the **Gears** menu.

-
- 3 Press and hold the RED button to enter the **Gears** menu. **Enabled** is displayed.
 - 4 Click the GREEN button to display **Yes**. The gear selection feature is now enabled.
 - 5 Click the RED button until **type** is displayed.
 - 6 Click the GREEN button until **Auto** is displayed. The Auto selection feature is now enabled.
 - 7 To set the number of gears, click the RED button until **No of Gears** is displayed.
 - 8 Click the GREEN button to enter the number of gear ratios that you have.
 - 9 Press and hold both RED and GREEN buttons until the normal display is shown.
 - 10 Drive the vehicle, using all of the gears.

Once you have used all of the gears, the X Sport will start to display the gear numbers.

If you have previously enabled the gear display feature:

- 11 Use the **Reset** function to reset the gear calibration. Press and hold the RED button for 2 seconds.
- 12 Scroll through the menu headings using the RED button until **Gears Calib** is displayed. Press the GREEN button to reset the gear calibration.

Resetting the gear calibration automatically starts the X Sports gear learning mode.

- 13 Drive the vehicle, using all of the gears.

Once you have used all of the gears, the X Sport will start to display the gear numbers.

Setting up the User selection feature:

The X Sport must be told when you are in the ratio that it is looking for. The number of the ratio that the X Sport is looking for is displayed, and you then tell the X Sport that the ratio is correct by a short press of the RED button. The X Sport will then move on to the next ratio until all have been stored. The ratios must be in order as the User mode cannot sort the ratios like the Auto mode.

If this is the first time that you have set up the gear display, you will need to enable all of the features before setting it up. Follow the steps below. If you have already enabled the gear display feature, go straight to step **10**.

- 1** Press and hold both RED and GREEN buttons until **Setup** is displayed.
- 2** Click the RED button to scroll through the menu options until you come to the **Gears** menu.
- 3** Press and hold the RED button to enter the Gears menu. **Enabled** is displayed.
- 4** Click the GREEN button to display **Yes**. The gear selection feature is now enabled.
- 5** Click the RED button to scroll through the menu options until **type** is displayed.
- 6** Click the GREEN button until **User** is displayed. The User selection feature is enabled.
- 7** To set the number of gears, click the RED button to scroll through the menu until **No of Gears** is displayed.
- 8** Click the GREEN button to enter the number of gear ratios that you have.
- 9** Press and hold both RED and GREEN button to exit the **Setup** menu.

If you have previously enabled the gear display feature:

- 10** Reset the gear calibration. Press and hold the RED button for 2 seconds.
- 11** Scroll through the menu headings using the RED button until **Gears Calib** is displayed.
- 12** Click the GREEN button to reset the gear calibration.
- 13** The X Sport will display the number of the ratio that it wants to configure. Drive the vehicle, select this ratio and press the RED button. The X Sport will configure this ratio and move to the next until all ratios have been recorded.

Adding a filter to your RPM or wheelspeed signals

If your RPM or wheelspeed signals have interference on them, they will have an adverse affect on the Automatic gear numbering feature. If you are having difficulty using the Automatic gear display feature this could be why.

To add a filter to your Speed input signals:

- 1** Press and hold both RED and GREEN buttons until **Setup** is displayed.
- 2** Click the RED button to scroll through the menu options until you come to the **Gear** menu.
- 3** Press and hold the RED button to enter the **Gear** menu.
- 4** Click the RED button to cycle through the options until **Filter** is displayed.
- 5** Click the GREEN button to select a filter value from 1 to 5.

The lowest or weakest filter is 1, and 5 is the highest or strongest filter. The stronger the filter, the more stable the RPM and speed values will be, but the X Sport will take longer to change the ratio display. This will stop the wrong ratio from being displayed if the signals are subject to interference.

- 6** Press and hold both RED and GREEN buttons to save the setting and return to page A.

Setting up the gear number using a gear position sensor

This gear number option requires a gear position sensor (potentiometer) to be connected to the Fuel pressure inputs, which are labelled **P2 Signal** and **P2 Power** on the loom.

Before setting up gear numbers using this method make sure that the Gear Ratio set up is not enabled.

To disable the Gear ratio display:

- 1 Press and hold both RED and GREEN buttons until **Setup** is displayed.
- 2 Click the RED button to scroll through the menus until you come to the **Gears** menu.
- 3 Press and hold the RED button to enter the **Gears** menu. **Enabled** is displayed.
- 4 Click the GREEN button to display **No**. The gear selection feature is now disabled.
- 5 Press and hold both RED and GREEN buttons to exit **Setup**.

To set up gear numbers using a gear position sensor:

- 1 Fit a potentiometer to the gear box so that the output of the potentiometer depends upon the gear selected.
- 2 Connect the output from the potentiometer to the Fuel pressure (P2) input channel.
- 3 Press and hold the RED and GREEN buttons so that the X Sport goes into Setup mode.
- 4 Click the RED button until the **Options** page appears.
- 5 Press and hold the RED button until the **ORM** page appears.
- 6 Click the RED button until the **Gears** page appears.
- 7 Click GREEN button to select the number of gears you have.
- 8 Click the RED button. The **Gear** setup page appears, displaying **n** for neutral in display field 2.

The raw count from the gear box potentiometer is shown in the bottom left display field (field 4).

-
- 9 Select neutral gear position on the gearbox.
 - 10 Press and hold the GREEN button for 2 seconds. The raw count input for neutral gear is transferred to the top right display field (field 3) and stored in the X Sport.
 - 11 Click the GREEN button. The gear number display changes to 1.
 - 12 Select first gear in the gearbox. The raw count for first gear is shown in the bottom left display field (field 4).
 - 13 Press and hold the GREEN button for 2 seconds. The raw count is then transferred to the top right display field (field 3) and is stored in the X Sport.
 - 14 Click the GREEN button. The gear number display changes to the next gear, ready to record the raw count for that gear.
 - 15 Select the next gear. The raw count for the gear is displayed in the bottom left display field (field 4).
 - 16 Repeat steps 13 to 15 to store the raw count for all the gears.

After all gears been set up you can check the stored values by clicking the GREEN button. A gear number and its stored value are displayed at each click.

- 17 When you have finished setting all the gears, press and hold the RED and GREEN buttons so that the X Sport returns to Realtime Page A mode.

The Gear number can be viewed on **Realtime Page B** in display field 4 before the vehicle has been driven. In Race mode the gear number is shown in the page ident display field (field 2) of the X Sport.

At the track

Initial checks

This section takes you through a typical day of using a X Sport.

If you have not used a X Sport before, you may need to refer to the *Setup* section.

Track kit list

For a typical day using X Sport:

If you have the ORM option you will need:

- a laptop PC with ORM software installed
- ORM download lead.

If you have a beacon kit, you will need:

- the beacon transmitter and power lead
- a battery to run the beacon transmitter (7.2V for a single channel beacon or 12V if you are using a 10-channel beacon).

Note: A Monster beacon transmitter, set to channel 0, is installed at major tracks in the UK. To use this transmitter you must set your beacon detector to channel 0. You do not then need to use your own beacon transmitter.

In case of accident damage, we suggest you have:

- a basic toolkit (including crimping tool)
- a spare wheel speed sensor
- a spare temperature sensor
- a spare pressure sensor.

Checklists

Before each outing, check that:

- the X Sport is powered up
- the X Sport has been setup properly for the vehicle
- the sensors are working properly (click the GREEN button to switch between Realtime Page A and Realtime Page B to check the sensor values, e.g. car battery voltage, or RPM)
- the wheel speed sensor is adjusted correctly (spin the wheel) and view Realtime Page A—the decimal points in display field 1 are illuminated when the sensor detects a trigger
- the sensor wiring has not been damaged, if you've been working on the vehicle.

If you have a beacon kit, check that:

- the beacon transmitter is wired up and working (check the front light on the transmitter)
- the beacon transmitter and detector are set to the same channel
- the beacon receiver is working (wave the transmitter in front of it and check that the decimal points in display field 5 are illuminated when a beacon transmitter signal is detected)
- the beacon transmitter is placed on the pit wall at the same height as the detector
- the battery is fully charged
- you remember to pick up your transmitter after the race!

Note: The lap times are stored in the X Sport, not in the beacon transmitter. This means that all the cars in your team can use the same beacon channel with a single transmitter.

If you have your own beacon transmitter, each time you visit a circuit, try to place the transmitter at exactly the same place on the pit wall.

A typical day...

Once you have completed the check lists, you are now ready to go.

The diagram below shows a typical day's use of an X Sport.

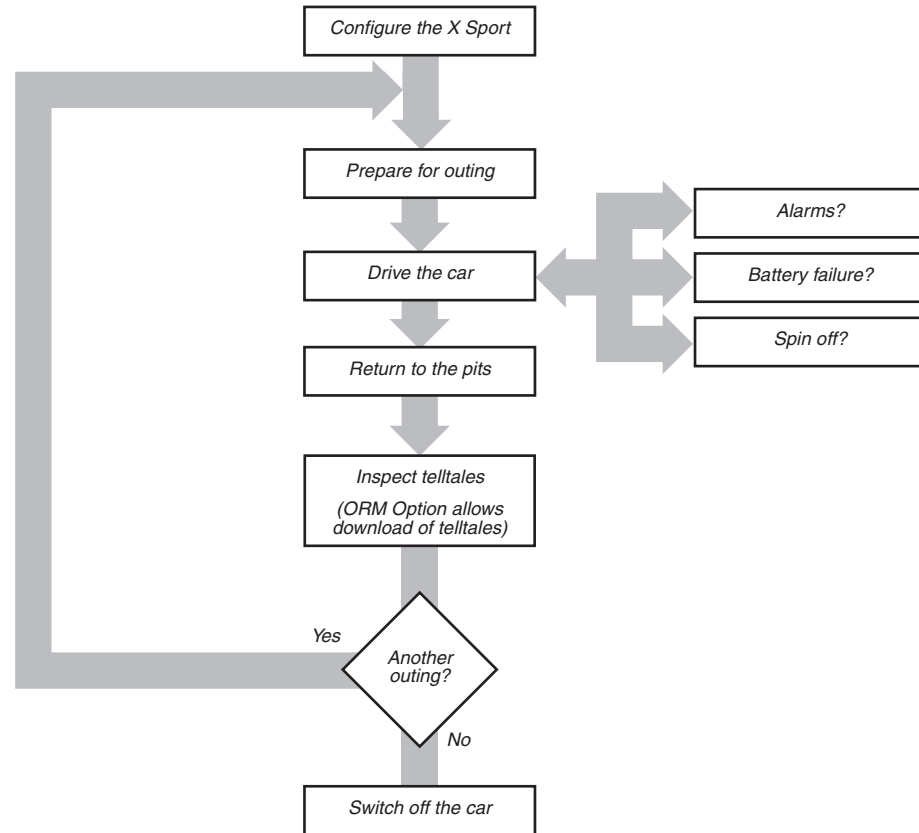

Preparing for an outing

Powering up the X Sport

Turn on the master switch (and ignition switch, if necessary) to power up the X Sport. The X Sport starts up in Power up mode and after a selftest lasting a few seconds, changes to Realtime mode Page A.

Check the setup of the X Sport

The first time you use the X Sport, check that it is correctly setup (see the *Setup* section).

Warming up the car

- 1 Start the engine.

Use the X Sport to monitor temperatures and pressures whilst you warm the vehicle up in the pits.

- 2 Click the GREEN button to switch between Realtime Page A and Realtime Page B.

Realtime Page A shows:

- wheelspeed sensor output (2 digits only)
- coolant temperature
- oil pressure
- RPM.

Realtime Page B shows:

- wheelspeed sensor output (2 digits only)
- oil temperature
- fuel pressure
- battery volts.

Driving the car

The car is now ready to drive.

As you leave the pits and pass the outing speed, the X Sport switches to the Race page and starts recording data for the Telltale pages. The X Sport can record data for a maximum of 45 laps.

Race page shows:

- Lap number
- Letter r (or Gear number if you have stup gears)
- Minimum latched speed
- Real time speed or Latched maximum speed (depends on which option was selected in Setup Mode)
- Lap time (if you have a beacon fitted)

To return to Realtime Page A or Realtime Page B at any time:

- 1 Click the RED button until the page you want is displayed.

Lap Times

As you drive past the beacon transmitter, the time for your last lap appears on the Race page. Race page also shows a lap count.

Note: If a wheelspeed sensor is not fitted, Lap Times will not be displayed.

Spinning off

If you spin off and do not stall the engine, the X Sport remains in Race mode and continues to record telltale data.

If you stall the engine and the car stops, the X Sport will switch to Telltale mode. If you then restart the engine and start moving again, once the Out speed has been exceeded, the X Sport automatically switches back to Race mode. **ALL previous telltale data is lost** and the X Sport starts recording new telltale data as though it were on a new Outing.

Alarms

The X Sport will trigger an alarm if thresholds for any of the following parameters are exceeded:

- Maximum Coolant temperature
- Maximum Oil temperature
- Minimum Oil or turbo pressure
- Minimum Fuel or turbo pressure
- Minimum Battery voltage

When an alarm is triggered, the alarm light is illuminated. An alarm message and the value of the parameter causing the alarm are also displayed. The message is the same as that displayed when setting the alarm thresholds in Setup mode.

After an Alarm has been generated, the thresholds are automatically adjusted after 30 seconds (until the dash has been reset), preventing alarms from re-triggering after a spin:

- Temperatures +5°C
- Pressures -5psi
- Battery Voltage -0.5V

Alarm prevention

To prevent alarms being set off unnecessarily, they are only triggered in Race Mode.

Note: If a wheelspeed sensor is not fitted, Alarms will not be triggered.

Setting Alarm thresholds

You set the Alarm thresholds when the X Sport is in Setup mode; see the *Setup* section.

To cancel an Alarm:

1 Click *either* RED or GREEN button to reset the alarm.

If the reading is still significantly in error from the automatically adjusted threshold, the alarm will continue to be generated and must be reset each time until enough resets have been made to ensure that the reading no longer exceeds the threshold setting.

If the problem (e.g. low fuel pressure) is temporary, the alarm will reset itself and the threshold will **not** be adjusted.

Note: After a manual reset, alarm thresholds are reset to their original value only when the X Sport is reset.

Battery alarm

The X Sport requires a minimum battery voltage (7.0V) in order to operate. If the vehicle battery delivers less than this, the Battery alarm will alert you when the battery is running low. The threshold for the Battery alarm can be set in Setup mode.

Returning to the pits

Inspecting telltales

If you have the ORM option you can download the Telltales to the PC. You can also view the telltales directly on the X Sport.

When you stop and switch the engine off the X Sport automatically changes to Telltale mode, and displays Telltale Page C. The data displayed on Telltale Page C is for the fastest lap in the outing.

The highest maximum value and lowest minimum value for the parameters for an outing on each telltale page are shown when the Lap number field displays **tt**.

Telltale Page C displays the following parameters for the *fastest lap* of the outing:

- Lap number
- Lap time
- Minimum speed
- Maximum speed.

You can then choose to scroll through the above parameters for all the laps in the outing, or choose to view the remaining two Telltale Pages.

1 Click the GREEN button to change the lap.

OR

2 Click the RED button to select Telltale Page D.

Telltale Page D displays:

- Lap number
- Maximum coolant temperature
- Minimum oil pressure
- Maximum RPM.

3 Click the GREEN button to change the lap.

OR

4 Click the RED button to select Telltale Page E.

Telltale Page E displays:

- Lap number
 - Maximum oil temperature
 - Minimum fuel pressure
 - Minimum battery voltage.
- 5 Click the GREEN button to change the lap.

Note: The first lap driven in an outing is always called the Out lap. The last lap driven in an outing is always called the In lap.

Switching off the car

Once the car has come into the pits and you have checked the Telltale Pages, (or you have downloaded the Telltales data to the PC if you have the ORM option) it is safe to turn off the X Sport.

Note: Removing power from the X Sport will destroy the Telltale data recorded in the X Sport.



Installation

Fitting the X Sport and sensors

Wiring notes

The wire used in the X Sport loom is abrasion resistant and rated to 150°C.

Cables should not be run next to sources of interference, i.e. ignition coils, plug leads, alternators, fuel pumps, radios and ECUs. If it is absolutely necessary to run the cables near any of these, avoid parallel runs if at all possible.

Care should be taken in the routing of the cables around the engine or brake areas, as localised heating when the vehicle is stationary can cause damage to the wiring.

Power supply

To avoid any problems, the X Sport unit should be treated as a separate system and only connected to the vehicle at the battery and Master switch. It should not share its wiring with other systems or items on the vehicle

On racing cars, the negative side of the supply battery is conventionally connected to the vehicle chassis through a Master switch. This allows total disconnection of all electrical power in an emergency, and is required by the regulations governing all motor sports.

The X Sport should be connected directly to the 'safe' side of the Master switch, to ensure the safety of the installation. The positive supply to the display should be fed directly from the battery 'live' terminal, or optionally through a separate switch, which allows the display to remain powered up while the ignition systems are off.

You can also power the X Sport from a separate 12 volt battery when using it, for instance, on a kart.

Fitting the X Sport

Although the X Sport has been designed to be fitted to a steering wheel, it can be fitted to a vehicle dash.

X Sport dimensions

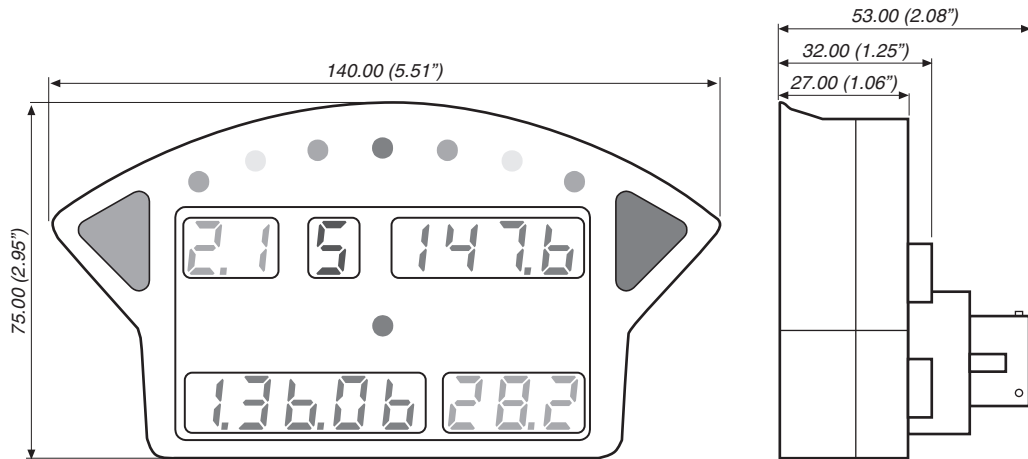

X Sport dimensions in millimetres and (inches)

Fitting X Sport on a steering wheel

Use a bracket to fit the X Sport to a steering wheel. You can make your own bracket, but a bracket, part number 10D-032440, is available from Pi Research. This bracket is designed to fit the X Sport to a 10" steering wheel.

CAUTION: TORQUE THE SCREWS FIXING THE BRACKET TO THE X SPORT TO 5Nm.

A coily loom, part number 60D-032434, to connect between the System Loom Dash AutoSport connector and the connector on the rear of the X Sport is available from Pi Research.

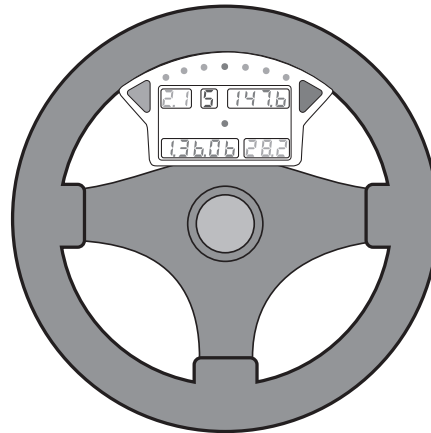

X Sport fitted in a steering wheel

Fitting X Sport in a vehicle dash

The X Sport is designed to fit to a steering wheel, but it can be fitted to a vehicle dash.

- 1 Remove any existing displays from the vehicle.
- 2 Check the clearance available behind the dash, to make sure there is room for the X Sport loom and connectors.

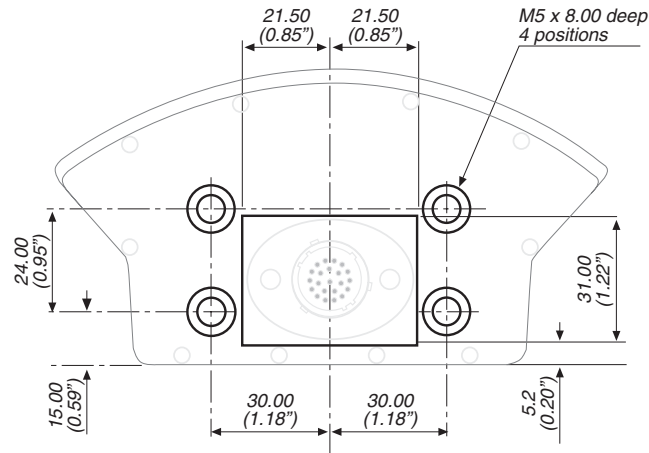

Rear view of the X Sport showing mounting holes. Dimensions in millimetres and (inches)

- 3 Mark up the dash panel with the location of the mounting holes as shown in the above figure.
- 4 Drill the location holes for the mounting screws and the Autosport connector.
- 5 Mount the X Sport on the dash panel.

CAUTION: TORQUE THE SCREWS FIXING THE X SPORT TO THE DASH PANEL TO 5Nm.

Notes

- Make sure that there is space behind the dash panel for the cables to exit.
- Do not bend the looms so that they place a strain on the connectors.
- The X Sport should be mounted so that the driver can see the display through the steering wheel.

Wheelspeed measurement

Wheelspeed sensor

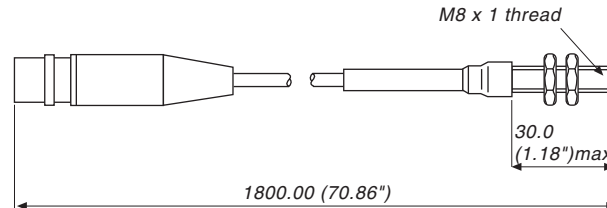

Wheelspeed Sensor

Sensing Distance	0.4mm to 0.8mm	
Clearance Distance	8mm from any steel object	
Mounting	30mm of M8 x 1 thread DO NOT OVER-TIGHTEN. THE MAXIMUM TORQUE IS 4Nm.	
Connector	3-pin Cannon SureSeal	
Sensor connections	Pin 1 (Blue)	Ground
	Pin 2 (Black)	Signal
	Pin 3 (Brown)	Power

Failure to have the minimum clearance from other steel objects causes the sensor to register a rotation even though the trigger target has moved out of range. On the other hand, if the working distance is too great, the sensor will miss triggers, especially at slow speeds.

WARNING: The sensor should only be tightened with a small spanner. Over-tightening the sensor will cause it to fracture. Use the locknuts provided to secure the sensor. The maximum torque is 4Nm.

Wheelspeed Trigger

Type	ferrous metal object
Number	1 to 30 per wheel revolution (typically 2 or 4)
Size	nominally 8 x 8 x 4mm

The trigger used to activate the wheelspeed sensor should have a surface approximately the same size as the head of the sensor, and be at least 4mm away from other metal objects.

On saloon cars, tolerances of 0.5mm can be hard to achieve so we suggest you use only one trigger.

The sensor can either be mounted in a threaded block, or with a sheet metal bracket. Make sure the sensor does not vibrate or touch the trigger when the vehicle is driven.

The X Sport can be used with a wide variety of vehicles, so the details of mounting the sensor will vary (installation data sheets for each type are available from Pi Research). Three examples of mounting configurations are shown in the following diagrams.

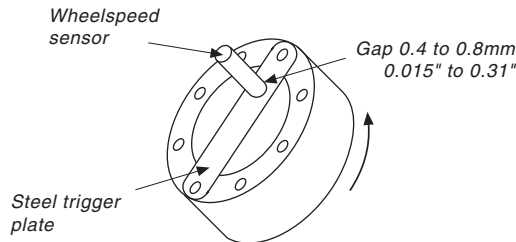

Top mounted configuration

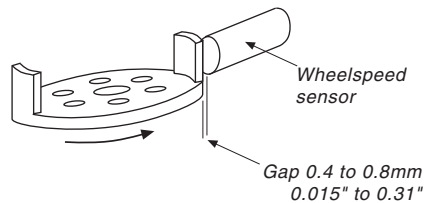

Side mounted configuration

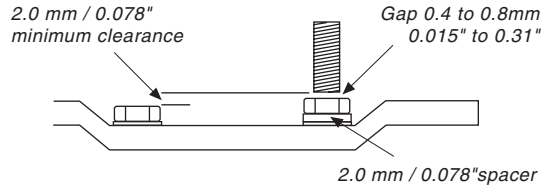

Wheel stud mounted configuration

Wheelspeed sensors

- 1 Make a bracket for the wheelspeed sensor and mount the sensor on the vehicle.

The sensor is normally mounted on the front nearside wheel, since this experiences the least wheel lift or lockup.

Do not over-tighten the wheelspeed sensor (**THE MAXIMUM TORQUE IS 4Nm.**)

Avoid mounting the sensor too close to the brake disc (to avoid superheating)

- 2 Secure the cable of the sensor on the wishbone and into the front nose cone (on a formula car), or through to the engine bay (on a saloon car).

Make sure the cable is not tight when the wheel moves or the wishbone is lowered.

- 3 Mount the wheelspeed trigger on the wheel.

See earlier description of trigger types. Make sure that the sensor head does not touch any of the triggers.

- 4 Set up the sensor with an approximate gap of 0.7mm (0.28").

Test that the wheelspeed is working

To test that the wheelspeed sensor is working correctly, set the X Sport to Realtime Page A and spin the wheel that is being used to trigger the wheelspeed sensor. The decimal points in the X Sport display field 1 should flash each time the wheelspeed sensor passes the wheelspeed trigger.

RPM measurement

The X Sport can measure engine RPM in three ways:

- a digital tachometer signal (vehicles with electronic ignition or ECU)
- the RPM box with Low Tension (LT) input (e.g. standard contact breaker ignition systems)
- the RPM box with High Tension (HT) input (e.g. electronic ignition systems where no tachometer signal is available).

The RPM box (01F-152080) generates its own tachometer signal from the LT or HT signals on the vehicle.

Tachometer signals

The X Sport unit can accept a tacho feed from most ECUs. The X Sport ECU loom includes a connection for an ECU.

A Tacho input connection loom (labelled Tacho input) has been included in kits C502 and C503. Only pin 2 has been connected; the ignition system and the X Sport must share the same earth.

If you have a low voltage digital tacho signal on your vehicle (from the ignition system or ECU), locate the wire and join it securely to the flying lead of the Tacho input connection loom. After joining the two leads, connect the plug into the RPM connector on the X Sport Loom.

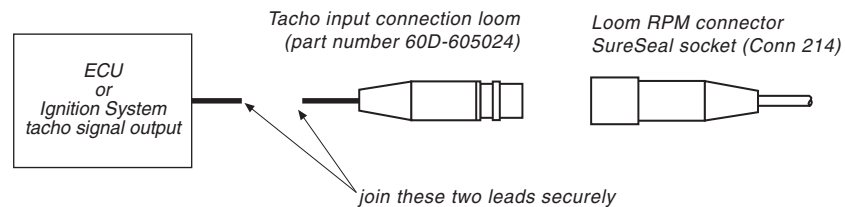

Tachometer connections

If the tacho signal is noisy (indicated by an unstable RPM at steady revs) then you will need to use a Pi Research 4-stroke RPM box (part number 01F-152080) to clean up the tacho signal. This RPM box has the correct type of connector to plug into the RPM connector on the X Sport loom. See section *Using an RPM box to clean up a noisy tacho input*.

The RPM box (part number 01F-152080)

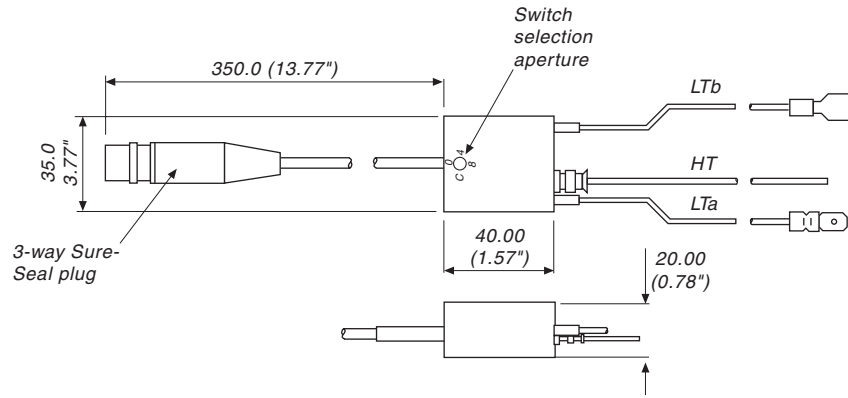

RPM Box

Mounting	Industrial Velcro®	
Connector	3-pin Cannon SureSeal	
Connections	Pin 1 (Green)	Ground
	Pin 2 (Blue)	Signal
	Pin 3 (Red)	Power

The RPM box either picks up current pulses from the LT side of the coil, or voltage pulses from the master HT lead or tacho signal input.

WARNING: To prevent damage, the LT or HT sources should not be directly connected to the X Sport.

The RPM Box should be fixed using Industrial Velcro®, near the ignition coil but not mounted to it. A suitable mounting position can usually be found which allows the LT connection to be made without extending the wiring provided.

RPM box HT connection

The HT (High Tension voltage) connection consists of a single wire running from the bullet connector in the RPM Box and wrapped around the HT lead of the vehicle. A piece of wire (high temperature rated) with a bullet connector has been included with the RPM Box for this purpose.

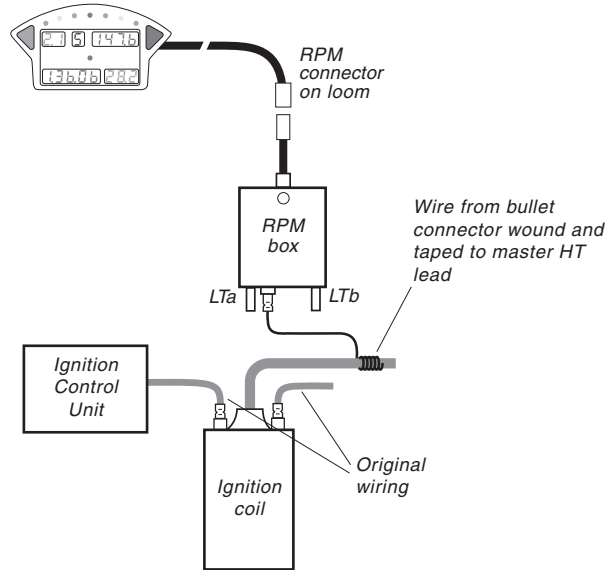

The RPM Box connected to HT lead

The wire should be wrapped around the master HT lead about five times: any excess can be clipped off and then secured with tape. The RPM box LT connections are not used and can be joined together and taped up.

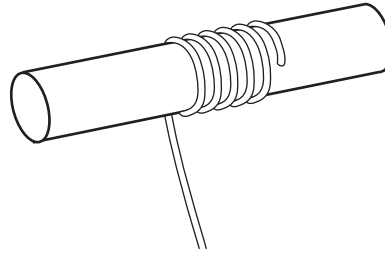

HT pickup – detail

Note: The RPM Box is sensitive to the polarity of the HT pulse it receives. If this causes a problem, try using the LT pickup method.

Using an RPM box to clean up a noisy tacho input

You can use a tacho signal to provide RPM input for the X Sport. If the tacho signal proves to be noisy (this is indicated by an unstable RPM reading at steady revs) you can use a Pi Research 4-stroke RPM box, part number 01F-152080, to clean up the tacho signal to the X Sport.

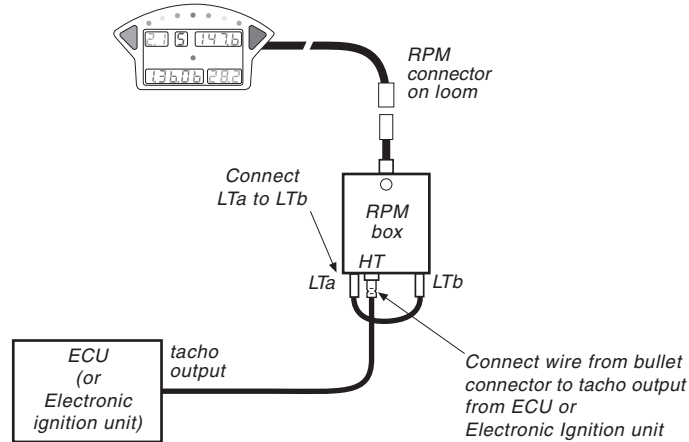

RPM box connection to clean up a noisy tacho input

To clean up the tacho signal you connect the tacho output to the HT connector on the RPM box. The HT connection consists of a single wire running from the bullet connector in the RPM box. A piece of high temperature rated wire, with a bullet connector fitted, has been included with the RPM box.

- 1 Connect the LTa and LTb terminals together.
- 2 Securely connect the tacho signal to the HT input on the RPM box.
- 3 Set up the RPM box as described on the following pages.
- 4 Set up the X Sport RPM menu.

Setting up the RPM Box

The RPM Box has a small 16-position switch which needs to be set to match the signal received. Legends for positions 0, 4, 8 and C (=12) are printed on the box, but the intermediate settings are available. Settings 0 to 7 should be used with LT (ignition coil) connections. Settings 8 to F should be selected if using the HT connection.

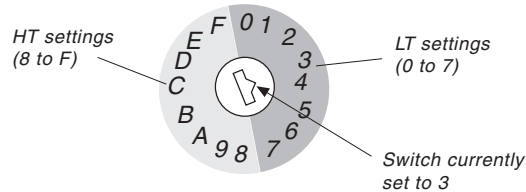

RPM box switch settings

The settings are related to the number of sparks per minute the engine needs at maximum RPM, as in the following table:

Max. sparks/min.	LT	HT	Typical example
11,000	0	8	11,000 RPM 2-stroke (11,000 sparks/min.)
19,000	1	9	7,500 RPM 4-stroke (15,000 sparks/min.)
36,000	2	A	V8 single coil 4-stroke (30,000 sparks/min.)
45,000	3	B	
54,000	4	C	
64,000	5	D	
85,000	6	E	
95,000	7	F	

Notes

- RPM measurement is more reliable when unwanted signals are filtered out. Setting the RPM box sets the frequency at which signals are filtered out, e.g. Setting 1 filters out signals higher than 19,000Hz.
- If the RPM reading on the dash starts to flash at high RPM, try increasing the setting by one or two positions.
- Do not be afraid of experimenting until you find the correct setting for your vehicle, as an incorrect setting will not damage the unit.

Example X Sport RPM setups

4-cylinder 4-stroke

A 4-cylinder, 4-stroke engine generating 2 sparks/revolution, at 7500 RPM maximum requires the RPM Box to respond to 15,000 sparks/min. The switch then needs to be set to 1 for LT pickup, or 9 for HT pickup.

RPM box switch setting	1 (LT)	9 (HT)
-------------------------------	---------------	---------------

X Sport RPM menu settings:

PULSES	4 [pulses per 2 revolutions]
--------	------------------------------

1-cylinder 2-stroke

A single cylinder, 2-stroke engine generating 1 spark/revolution, at 11,000 RPM maximum requires the RPM Box to respond to 11,000 sparks/min. The switch on the RPM Box needs to be set to 0 for LT pickup, or 8 for HT pickup.

RPM box switch setting	1 (LT)	8 (HT)
-------------------------------	---------------	---------------

X Sport RPM menu settings:

PULSES	2 [pulses per 2 revolutions]
--------	------------------------------

The X Sport assumes a normal 4-stroke engine that runs from one ignition coil. 1-cylinder 2-stroke engines fire on every rotation and appear as 2-cylinder engines.

4-cylinder 4-stroke with double coils

A 4-cylinder, 4-stroke engine with double coils generating 1 double spark/revolution per coil, at 13,500 RPM maximum requires the RPM Box to respond to 13,500 sparks/min. The switch then needs to be set to 1 for LT pickup or 9 for HT pickup.

Care must be taken to ensure that the RPM Box only picks up signals from one of the coils. Then set the RPM menu PULSES to 2.

Pressure measurement

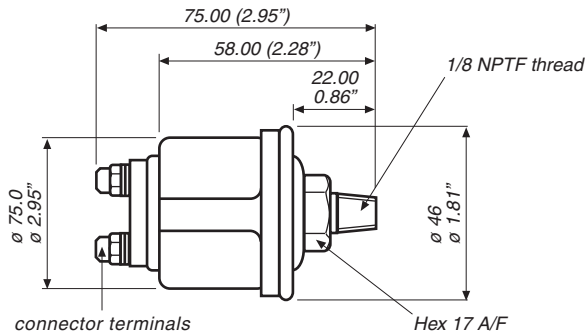

Pressure Sensors dimensions in millimetres and (inches)

Standard pressure sensor

Operating Range	0 to 200 psi 0 to 14.07 KGF 0 to 13.78 bar
Mounting	7mm 1/8 NPTF thread
Connector	2 off 4mm ring tag
Connections	non-polarized (5V and signal wires)
Explosion rating	35 bar

The same sensors are used for fuel and oil pressure measurement. The colour coded wiring on the loom determines how they should be connected (see Part B: Fitting the wiring loom).

The connections to the standard sensor are made using 4mm ring tags. They are unpolarised and can be connected either way around.

Other pressure sensors are available, which use spade connectors, instead of ring tags.

Mounting the pressure sensors

Indirect fitting

Mount the pressure sensors on a side pod near to the fuel/oil pumps using tie-wraps and rubber pads.

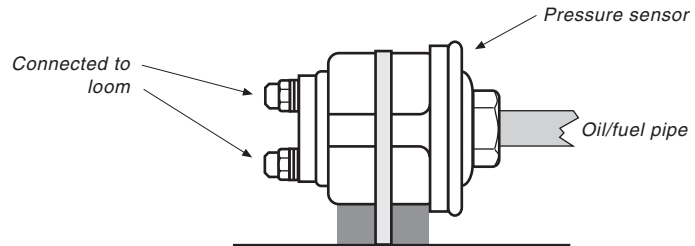

Indirect fitting of pressure sensors

Temperature measurement

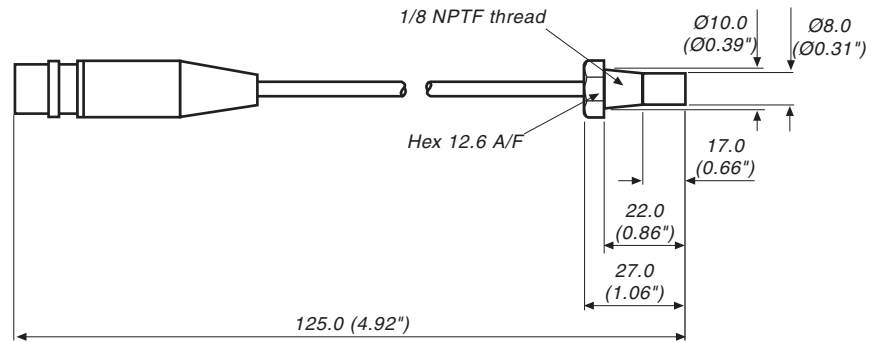

Imperial thread Temperature Sensor

Temperature sensor (Imperial)

Operating Range	0°C to 150°C (32° to 302°F)	
Accuracy	±2.5°C (±4.5°F)	
Mounting	7mm 1/8 NPTF thread 17mm extending past thread	
Connector	2-pin Cannon SureSeal	
Connections	Pin 1 (White)	Signal
	Pin 2 (Red)	Power (12V)

WARNING: The sensors can be adversely affected by water. Waterproof connectors have been supplied, but it is essential to use the silicone sealing compound to prevent water reaching the connectors from the loom wiring.

If water penetrates the connector, dry it out, reconnect, then seal using a silicone sealant.

The sensors for coolant and oil temperature are exactly the same. The colour coded wiring on the loom determines how they should be connected (see Fitting the wiring loom).

Mounting the temperature sensors

Mount the oil and coolant temperature sensors in the piping of the engine.

The coolant temperature sensor is normally mounted in the piping of the cooling system, either in an existing mounting point or by braising and threading an extra one.

The oil temperature sensor is normally mounted either in the sump area or in the piping of the oil pump.

Note: The sensors have their own earth, so earthing the body of the sensor or isolating it from the vehicle will have no adverse effect.

Optional equipment

Beacon receiver

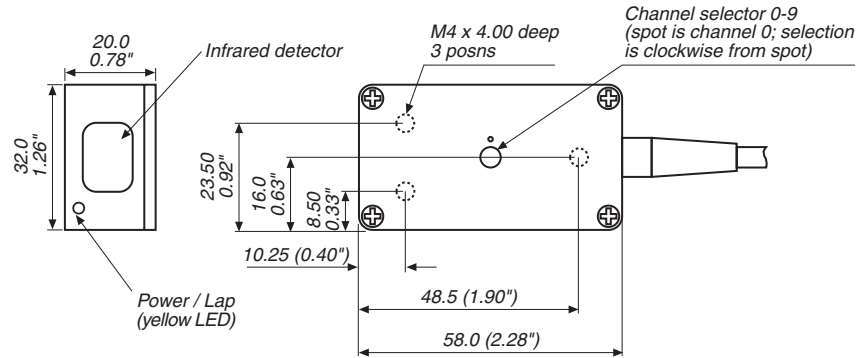

10-channel beacon receiver

The beacon receiver

Mounting	Industrial Velcro® or 3 off M4 holes in the base.	
Channels	0 to 9	
Connector	3-pin Cannon SureSeal	
Connections	Pin 1 (Green)	Ground
Pin 2	(Blue)	Signal
Pin 3	(Red)	Power (12 V)

Notes

- The beacon receiver should be mounted at right angles to the ground and at right angles to the direction of the vehicle in motion.
- Where possible, the receiver should be mounted flush to the skin of the vehicle, or recessed less than 25mm.
- Where possible, the receiving head should not face directly into the sun while detecting.

Test the installation of the beacon receiver

To test that the beacon receiver is working, set the X Sport to Realtime Page A. Wave a beacon transmitter in front of the beacon receiver and check that all five decimal points in display field 5 of the X Sport are illuminated when the beacon transmitter signal is detected.

Mounting the beacon receiver

The beacon receiver should be mounted so that it can point at either side of the track. It is often placed by the roll hoop or above the driver's headrest.

To mount the beacon receiver use Industrial Velcro® (supplied by Pi Research) or the 3 off M4 holes in the base.

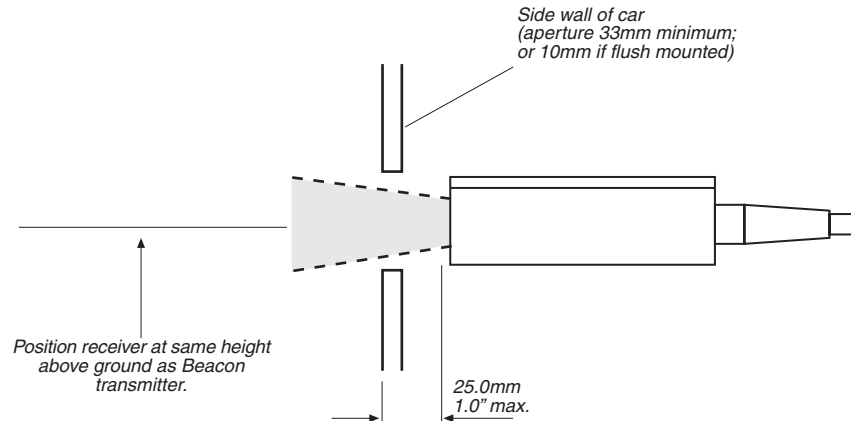

Beacon receiver placement

Beacon transmitter

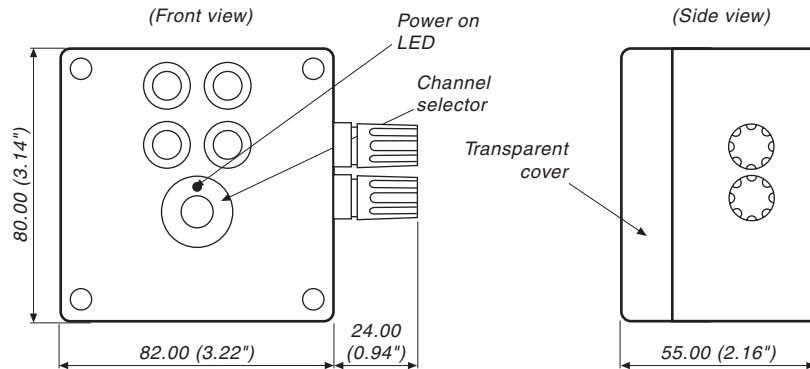

10 channel beacon transmitter

10 channel beacon transmitter

Mounting Industrial Velcro® or tape

Channels 0 to 9

Connector 2 screw posts

Connections Red post +12V; Black post 0V

Notes

- A fully charged 12V vehicle battery or rechargeable dry cell battery can be used to run the beacon transmitter.
- Make sure that the channels selected on the receiver and transmitter are the same.
- The transmitter should be mounted at the same height as the receiver on the vehicle, with the transmitter beam pointing horizontally and aimed straight across the track. Make sure the receiver is not pointing into the sun when it passes the transmitter.

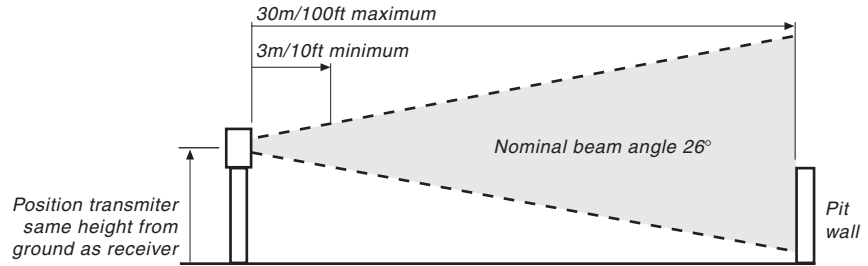

Siting a beacon transmitter (driver's view)

Ideally there should only be one beacon transmitter used at a track, but if several beacon transmitters are in use, do not place them so close together that their beams interfere with one another, as this could give rise to spurious lap times. The following diagram shows the minimum separation distances to be observed.

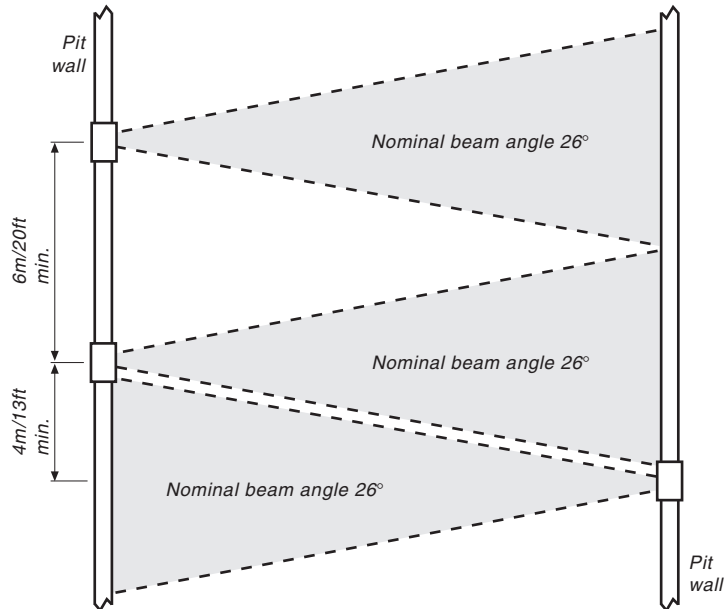

Minimum separation of transmitter beacons (plan view)

Sensors and interface boxes

There are range of sensors and interface boxes available for use with your X Sport. These can replace some of the standard sensors supplied.

The table below details which sensors and interface boxes can be used on which channels. Please note that the X Sport channels are pre-calibrated and cannot be used with alternative sensors unless they appear in the table.

Standard Channel	Alternative Use	Optional sensors
Wheelspeed	ABS wheelspeed	ABS sensor interface box
	Boat speed	Waterspeed sensor
	Fastest/slowest wheel speed	Wheelspeed selector box
RPM	RPM	Tacho pulse input
Oil temperature	EGT	Thermocouple + amp
Oil pressure	Turbo pressure	Pressure sensor (low)
	Carburettor pressure	Pressure sensor (low)
Fuel pressure	Turbo pressure	Pressure sensor (low)
	Carburettor pressure	Pressure sensor (low)
	Sequential gear position	Depends on gearbox design

ABS sensor interface box

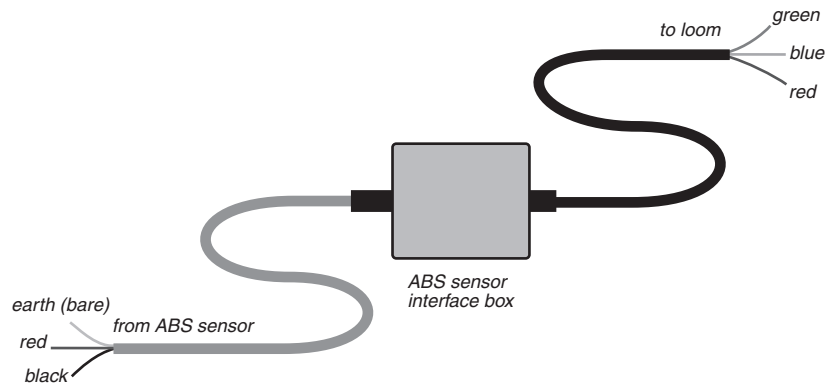

ABS sensor Interface Box

The Grey lead connects to ABS sensor. The Black lead connects to the wheelspeed connector on the X Sport loom

ABS sensor interface box

Mounting Industrial Velcro®

ABS sensor connections		Comment
Maximum input freq.	99 pulses per wheel revolution	
Connector	Un-terminated	
Connections	Foil	Screen (do NOT connect)
	Red	Signal
	Black	Reference

The X Sport ABS interface box connections

Connector	Un-terminated or 3-pin Canon SureSeal		
Connections	Pin 1	Green	Ground (0V)
	Pin 2	Blue	Signal
	Pin 3	Red	Power (12V)

The ABS sensor interface box enables the X Sport to take wheelspeed information from an existing ABS (Anti-lock Brake System) speed sensor. ABS speed sensors provide a robust wheelspeed measurement on touring and rally cars where mounting of the standard X Sport wheelspeed sensor might provide difficult.

The interface box has been designed for use with two wire ABS speed sensors (passive type).

WARNING: If the ABS speed sensor is also used by the ABS system on the vehicle, the two wires from the X Sport interface box should be connected to the sensor connections via 100 μ F 16V capacitors, with the negative side of the capacitor going to the sensor. If in doubt please contact your Pi representative.

DO NOT CONNECT ANY WIRES DIRECTLY TO THE CHASSIS OF THE VEHICLE.

Waterspeed sensor

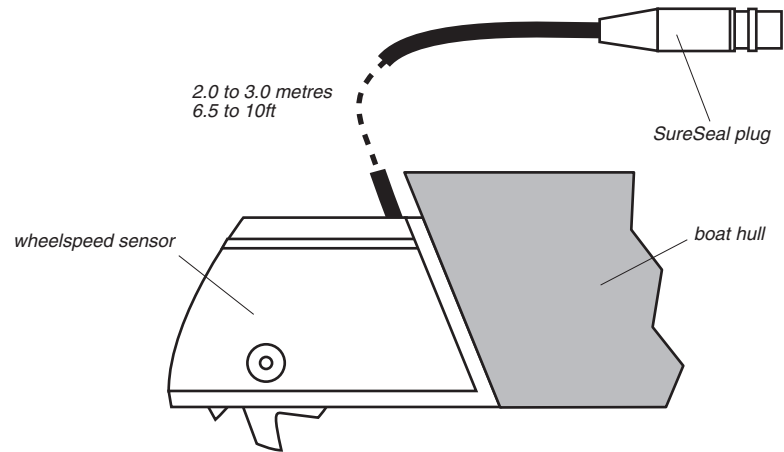

Waterspeed Sensor attachment

Waterspeed sensor

Sensing type	Hall effect pick-up off 6 point paddle wheel		
Mounting	Via two 5mm mounting slots		
Mounting position	On boat's transom in smooth water flow		
Connector	3-pin Cannon SureSeal		
Connections	Pin 1	Shield	Ground
	Pin 2	Orange	Signal
	Pin 3	Blue	Power (5–12V)
		Yellow	No connection

The waterspeed sensor can be used to measure boat speed through the water. The sensor can measure the effective speed of offshore boats which may be out of the water up to 50 percent of the time.

The sensor should be mounted on the boat's transom where the flow of water is least turbulent. The left (port) side of the transom is preferable; if it is impractical to mount it there, the right side can be used. Don't mount the sensor behind strakes or ribs, as these disturb the water flow to the speed sensor. Also make certain that the sensor will remain in the water even when the boat is on plane. The sensor is generally mounted about one foot from the boat's centre line.

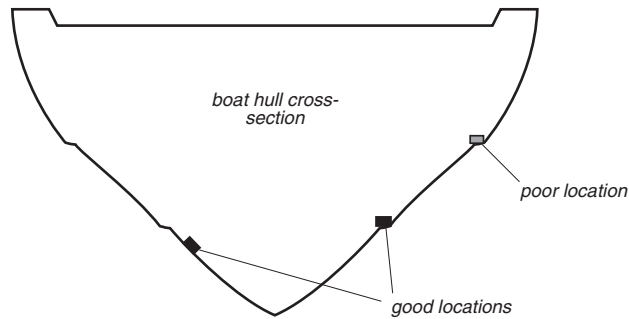

Positioning the Sensor on the hull

When setting 'tyre size' and 'triggers' on the dash, try using 650mm and 20 pulses/rev. A hand held Global Positioning System can be used to check the calibration. If you experience any problems, contact Pi Research.

Wheelspeed selector box

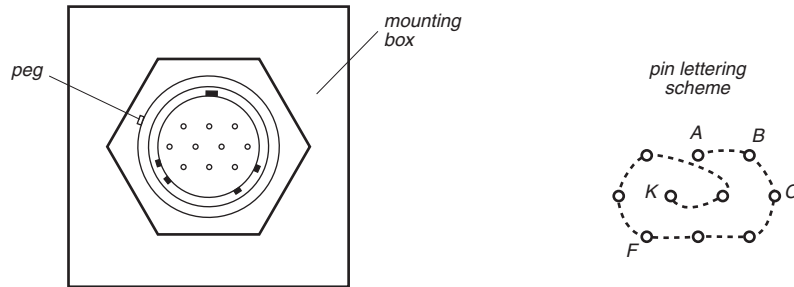

Wheelspeed selector box connector pinout

Wheelspeed selector box

Mounting	Industrial Velcro®	
Supply voltage	6–18V	
Supply current	4mA	
Connector	KPT 2E 12-10P (Cannon or equivalent)	
Connections	Pin A	Wheelspeed 1 sensor signal
	Pin B	Wheelspeed 1 sensor reference
	Pin C	Wheelspeed 1 screen
	Pin D	Wheelspeed 2 sensor signal
	Pin E	Wheelspeed 2 sensor reference
	Pin F	Wheelspeed 2 screen
	Pin G	Supply 0V from dash
	Pin H	Fastest wheelspeed signal to dash
	Pin J	Supply 12V from dash
	Pin K	Slowest wheelspeed signal (5V only)
	Fastest signal (H)	Open drain output which can be connected to the X Sport
Slowest signal (K)	Open drain output which can be connected to the X Sport	

The wheelspeed selector box monitors any two ABS speed sensors and outputs the fastest and slowest values. The fastest speed should be used in applications where wheels may lock during severe cornering (e.g. touring cars). The slowest speed should be used in applications where wheels may spin due to poor traction (e.g. rallying).

The dash must be set up for the number of triggers on the ABS sensor wheel.

If the ABS speed sensor wires are long or run through an electrically noisy environment, it may be advantageous to use screening braid. This should only be connected to the selector box and must not be allowed to earth to any metalwork on the vehicle.

WARNING: The 12V supply (Pin J) for the selector box should come from the X Sport, not directly from the vehicle battery.

Do not connect supply 0V (Pin G) if the ABS speed sensors are earthed.

Turbo/carburettor pressure sensor

The low pressure sensor has the same physical dimensions as the standard X Sport pressure sensor.

Turbo/carburettor pressure sensor

Operating Range 0-40 psi (0 to 2.5 bar)

Mounting 7mm 1/8 NPTF thread

Connector 2 off 1/4-inch female blade

Connections non-polarised

Explosion rating 35 bar

This low range pressure sensor can be used to measure turbo charger pressure or carburettor fuel pressure. The sensor reads down to 0 psi. Care must be taken when attempting to measure carburettor pressure: pressures caused by lateral or longitudinal g may generate pressure readings to the same level as those caused by draw of the carburettor.

The relevant pressure channel must be configured as **tbar** under the Setup **UNITS** menu.

Thermocouple sensor

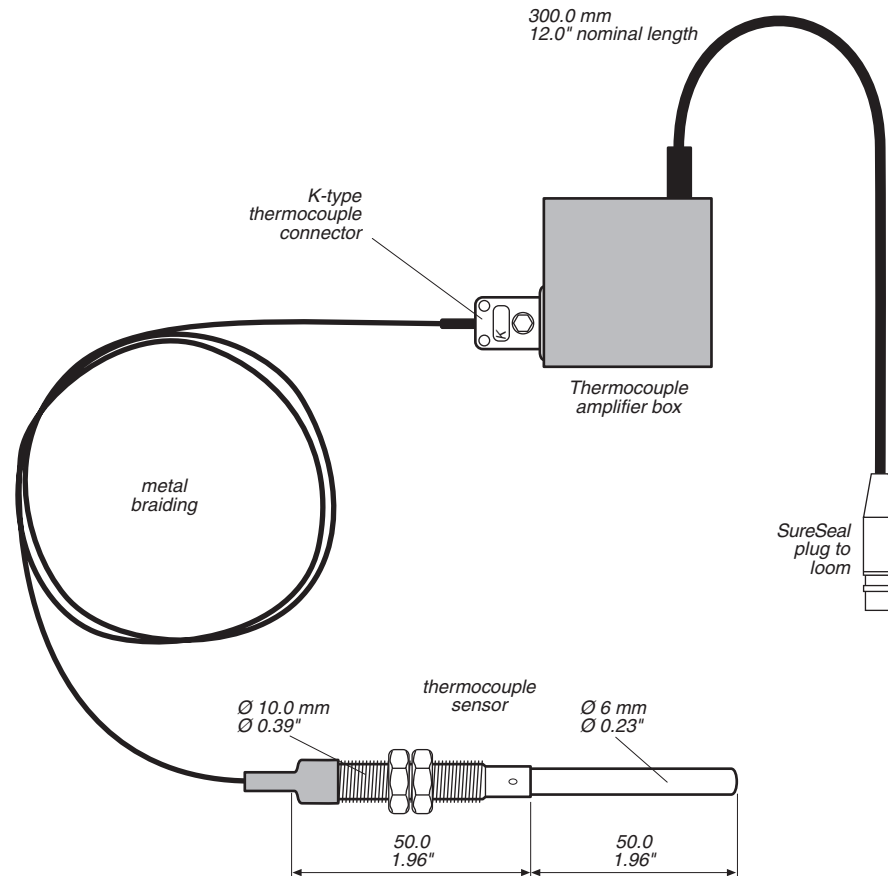

Thermocouple sensor

Thermocouple probe and amplifier

Probe

Operating range	100°C to 999°C		
Mounting	With lock nuts		
Connector	K-type		
Connections	Blue		-ve
	White		+ve

Amplifier

Mounting	Velcro		
Sensor connector	K-type		
System connector	3-pin Cannon SureSeal		
Connections	Pin 1	Green	Ground (0V)
	Pin 2	Blue	Signal
	Pin 3	Red	Power (12V)

The thermocouple is used to measure exhaust gas temperature (EGT) on vehicles with 2-stroke or 4-stroke engines. On 2-stroke karts, EGT is a good indicator of fuel mixture.

Extension leads can be used in conjunction with the sensor, but they must have the same metals and polarity.

Fitting a wirng loom

By this stage you should have mounted the X Sport and all the sensors on the vehicle. You are now ready to connect everything together.

X Sport looms

The X Sport is supplied with a loom. The loom length, specified at time of purchase can be one of the following:

- One metre long, terminated
- Three metres long, terminated
- Three metres long, terminated, for use with an ECU.
- Three metres long, un-terminated.

Fitting an Un-terminated loom

If you are fitting an Un-terminated loom refer to *Appendix B - Fitting an Un-terminated loom*.

Fitting a terminated loom for use with an ECU

If you are fitting a terminated loom for use with an ECU refer to *Appendix C - X Sport ECU loom information*.

Fitting a terminated loom

If you are fitting a terminated loom see below.

Connect the loom to the X Sport

Plug the AutoSport connector into the connector on the rear of the X Sport.

Lay the loom in the car

The wires for each of the sensors are tagged with their identity. Run the wires to each of the sensors on the car. Take care to avoid sharp metal edges and cables carrying high voltages (e.g. ignition circuits).

System supply

You may need to untwist the power and ground supply wires if the battery is at the front of the vehicle (connect red wire from loom) and the Master switch is towards the rear (connect black wire from loom).

Beacon

Run the beacon connections to a suitable position (e.g. by the roll hoop), even if you do not yet have a beacon kit.

Notes

- Run the cabling neatly along the chassis to the loom.
- Do not pull the cable taut either along the chassis or at joints and corners; instead, let the cable follow its natural path without excess tension.
- Use clamps at regular intervals to hold the cable to the frame. This will avoid kinking or cable damage.

Taping connectors

Where SureSeal connectors run along the chassis, tape around the outside of the sensor lead socket rather than each side of the plug and socket so that the connector pins are not pulled apart.



The correct and incorrect way to tape connections

Note: Make sure that there is enough room to make and break each connector.

Secure unwanted sensor wires

Isolate any wires you are not using near the dash and insulate the ends with tape. Keep the sleeve and wire idents on the loom to facilitate identification at a later date.

You should use tape at each branch point to hold the loom in shape.

Connect the sensors

Refer to the section *Wiring Details* for information on the connectors.

The Oil temperature, Coolant temperature, RPM, Wheelspeed, and beacon sensors are supplied terminated with 2-pin or 3-pin Cannon SureSeal connectors. Plug the sensor connectors to the relevant connector on the loom.

The pressure sensor connectors are ring tags. These are unpolarised 4mm ring tags and can be connected to either tag on the sensor.

Use the knurled finger nut and split washer to secure the ring tag to the sensor.

Note: Ensure that the split washer is between the ring tag and the knurled finger nut.

System checks and Power-up

Check the installation

Before turning the X Sport on, check:

- the clearance on the wheelspeed sensor
- the freedom of wires from moving parts
- the connector on the back of the X Sport

Turn the X Sport on

When you turn on the Master switch the X Sport powers-up. (Note that on some installations the ignition must also be turned on.)

Realtime page A is displayed. By clicking the GREEN button you can switch between Realtime page A and Realtime page B to view the values being measured on each sensor.

The road wheel can be rotated backwards and forwards to get the wheelspeed sensor to trigger.

The RPM display shows until the engine is running.

The battery voltage of the vehicle is displayed.

Once the X Sport has been configured to use a beacon receiver (see below), waving a powered beacon transmitter in front of the receiver causes lap times on the display to change. Make sure the channel settings on the beacon receiver and the beacon transmitter are the same.

Set up the X Sport

Before using the X Sport, you must set up it to show the correct RPM, Speed and Units, etc. If you are using a beacon, this must also be set on the X Sport. Refer to the *Setup* section.

Note: When you set up your X Sport please take time to write down the settings and have them available when seeking technical support from Pi Research.

Troubleshooting

All the troubleshooting hints are in a separate section. If you have any problems with your X Sport, refer to the section *Troubleshooting*.

Connector information

X Sport connector information

When the X Sport is used in Standalone Mode it displays data from sensors attached to the loom.

The figure below shows a terminated loom supplied by Pi Research. The loom can be one metre long or three metres long and is supplied pre-terminated. An un-terminated loom is also available. Refer to Appendix B if you have an un-terminated loom.

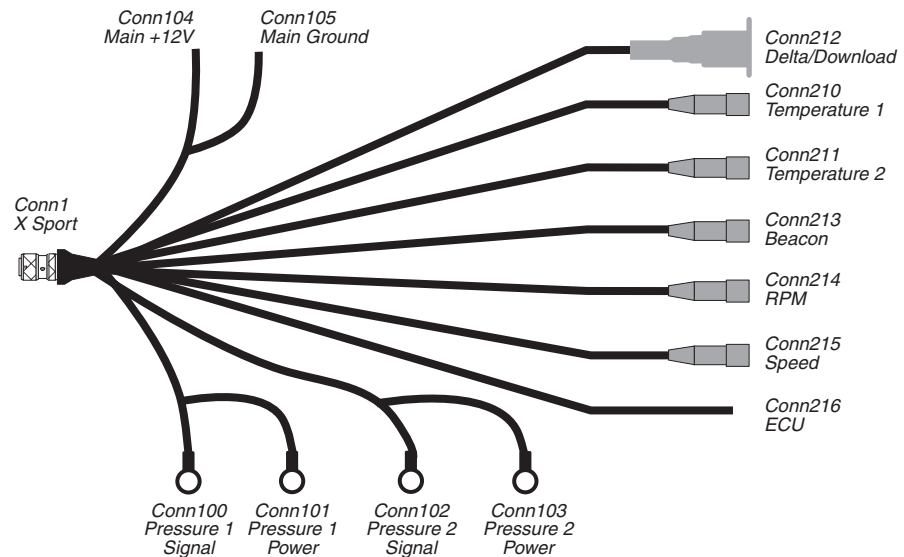

X Sport terminated loom

AutoSport (Conn1) connector details

Connector type: AS6-12-12-35SN Label: X Sport

Pin	Function	Dest1	Dest2	Comment
1	Pressure 1 Signal	Conn100-1		
2	Pressure 1 and 2 Power	Conn103-1	Conn101-1	
3	Temperature 2 Signal	Conn211-1		
4	Temperature 2 Power	Conn211-2		
5	Temperature 1 Signal	Conn210-1		
6	Temperature 1 Power	Conn210-2		
7	Data in to X Sport	Conn216-1		Can be GPS input
8	Data from X Sport	Conn214-4		
9	Main Ground	Conn105-1	Conn212-10	
10	Main +12V	Conn104-1	Conn212-8	
11	RPM Ground	Conn214-1		
12	RPM Signal	Conn214-2		
13	RPM Power	Conn214-3		
14	Pressure 2 Signal	Conn102-1		
15	Beacon Signal	Conn213-2	Conn212-6	
16	Beacon Power	Conn213-3		
17	Wheelspeed Ground	Conn215-1		
18	Wheelspeed Signal	Conn215-2	Conn212-5	
19	Wheelspeed Power	Conn215-3		
20	No Connection			
21	Beacon Ground	Conn213-1	Conn212-12	
22	No Connection			
Screen	Connect overall screen			

Connector 100

Connector type: 4mm ring. Label: P1 Signal

Pin	Destination - pin	Function
100-1	Conn 1 - pin 1	Pressure 1 signal
Screen	Isolate screen	

Connector 101

Connector type: 4mm ring. Label: P1 Power

Pin	Destination - pin	Function
101-1	Conn 1 - pin 2	Pressure 1 power
Screen	Isolate screen	

Connector 102

Connector type: 4mm ring. Label: P2 Signal

Pin	Destination - pin	Function	Comment
102-1	Conn 1 - pin 14	Pressure 2 signal	Can be used as gear input using a sensor (potentiometer)
Screen	Isolate screen		

Connector 103

Connector type: 4mm ring. Label: P2 Power

Pin	Destination - pin	Function	Comment
103-1	Conn 1 - pin 2	Pressure 2 power	Can be used as gear input
Screen	Isolate screen		

Connector 104

Connector type: Bare end. Label: Main +12V

Pin	Destination - pin	Function
104-1	Conn 1 - pin 10	Main +12V
Screen	Isolate screen	

Connector 105

Connector type: Bare end. Label: Main GND

Pin	Destination - pin	Function
105-1	Conn 1 - pin 9	Main GND
Screen	Isolate screen	

Connector 210

Connector type: Socket 2 way SureSeal. Label: Temp 1

Pin	Destination - pin	Function
210-1	Conn 1 - pin 5	Temperature 1 signal
210-2	Conn 1 - pin 6	Temperature 1 power
Screen	Isolate screen	

Connector 211

Connector type: Socket 2 way SureSeal. Label: Temp 2

Pin	Destination - pin	Function
211-1	Conn 1 - pin 3	Temperature 2 signal
211-2	Conn 1 - pin 4	Temperature 2 power
Screen	Isolate screen	

Connector 212

Connector type: Deutsch 12 pin, panel mounted. Label: Download/Delta

Pin	Destination - pin	Function
212-1	No connection	
212-2	No connection	
212-3	No connection	
212-4	Conn 1 - pin 8	Data from the X Sport
212-5	Conn 1 - pin 18	Speed signal
212-6	Conn 1 - pin 15	Beacon signal
212-7	No connection	
212-8	Conn 1 - pin 10	12V
212-9	No connection	
212-10	Conn 1 - pin 9	Data ground
212-11	No connection	
212-12	Conn 1 - pin 21	Beacon ground
Screen	Not required	

Connector 213

Connector type: Socket 3 way SureSeal. Label: Beacon

Pin	Destination - pin	Function
213-1	Conn 1 - pin 21	Ground
213-2	Conn 1 - pin 15	Beacon signal
213-3	Conn 1 - pin 16	+12 Volts for beacon power
Screen	Isolate screen	

Connector 214

Connector type: Socket 3 way SureSeal. Label: RPM

Pin	Destination - pin	Function
214-1	Conn 1 - pin 11	Ground
214-2	Conn 1 - pin 12	RPM signal
214-3	Conn 1 - pin 13	+12 Volts for RPM power
Screen	Isolate screen	

Connector 215

Connector type: Socket 3 way SureSeal. Label: Speed

Pin	Destination - pin	Function
215-1	Conn 1 - pin 17	Wheelspeed ground
215-2	Conn 1 - pin 18	Wheelspeed signal
215-3	Conn 1 - pin 19	+12 Volts for Wheelspeed power
Screen	Isolate screen	

Connector 216

Connector type: Bare wire Label: ECU

Pin	Destination - pin	Function
216-1	Conn 1 - pin 7	ECU data
Screen	Isolate screen	

Troubleshooting

Until you are completely familiar with your X Sport, you may encounter difficulties. This Section lists the most common sources of problems and how to correct them.

If the remedies suggested have no effect, please contact Pi Research.

WARNING: Do not attempt to repair Pi Research equipment yourself. The Warranty will be invalidated if any parts of the system have been tampered with.

X Sport

Problem	The dash doesn't start up
Cause	No supply voltage
Action	Check the car's master switch and ignition switch.
Cause	Flat battery
Action	Make sure the car battery is charged up and connected.
Cause	The connector on the dash is not secured.
Action	Check the connectors in the back of the dash are properly located.
Cause	Faulty wiring
Action	Check that the supply voltage wiring is not damaged or has been shorted out. (Refer to the Pin connection table in the 'Installation Notes' section.)
Problem	The dash blanks out
Cause	Supply voltage is dropping below 7 volts
Action	Check the battery is well charged.
Problem	The dash blanks out during use
Cause	Excessive electrical noise
Action	Check earthing of ignition or contact Pi Research
Cause	Faulty wiring
Action	Check that the supply voltage wiring is not damaged or has been shorted out. (Refer to the Pin connection table in the 'Installation Notes' section.)

Problem	The dash won't enter Setup mode whilst pressing and holding both the RED and GREEN buttons
Cause	This will occur if you have set the Options >Type> to DELTA
Action	Power cycle the X Sport whilst pressing and holding both the RED and GREEN buttons. This forces the X Sport into Setup mode.

Engine speed (RPM)

The X Sport

Problem	The dash is reading half the correct RPM value
----------------	---

Cause	The Pulse setting in the dash is wrong
-------	--

Action	Check and adjust the value in Setup mode.
--------	---

Problem	The Redline needs to be adjusted
----------------	---

Cause	The Redline setting in the dash needs to be adjusted
-------	--

Action	Check and adjust the value in Setup mode.
--------	---

Tacho signal

Problem	Unstable or absent RPM reading
----------------	---------------------------------------

Cause	The wiring is picking up noise from other sources on the car
-------	--

Action	Check whether the tachometer wiring runs close to other ignition circuits and re-route it if necessary.
--------	---

Cause	Wiring fault
-------	--------------

Action	Check that the tachometer signal from the ignition box (NOT the HT or LT ignition signals) is connected to pin 2 of the 3-way RPM connector on the loom.
--------	--

RPM Box (HT or LT mode)

Problem	The RPM readout is blank or intermittent
----------------	---

Cause	The loom connection to the RPM Box may be faulty
-------	--

Action	Inspect the 3-way connector on the RPM Box or System loom and repair, if necessary.
--------	---

Problem **The RPM reading is occasionally spiky**
Cause The wiring is picking up noise from other sources on the car
Action Check whether the RPM wiring runs close to other ignition circuits
 and re-route it, if necessary

RPM Box HT (High Tension) Connection

Problem **The RPM reading cuts out or flashes at high RPM**
Cause The RPM Box is not setup correctly
Action Check that the RPM Box is set for HT (positions 8 to F), and for
 the maximum sparks per minute that can be emitted by the
 ignition system.

Problem **The RPM readout is unstable**
Cause The HT connection on the RPM Box may be faulty
Action Inspect the wiring on the HT lead and repair, if necessary.

Problem **The RPM reading is obviously too low**
Cause The HT pickup has been wrapped around an HT lead to an
 individual cylinder instead of the main HT lead and is not picking
 up the sparks for the other cylinders
Action Wire the HT pick-up around the main HT lead.

Note: Some engines now have multi-coil systems, where each cylinder has its own coil. In these cases, you can use the HT lead from one coil if the PULSE value on the dash is adjusted accordingly (see the 'Installation Notes' section); alternatively, you could use the LT signal from the ignition box and drive the RPM Box in LT mode.

RPM Box LT (Low Tension) Connection

Problem **The RPM readout cuts out or flashes at high RPM**
Cause The RPM Box is not set up correctly
Action Check that the RPM Box is set for LT (positions 0 to 7), and for the
 maximum sparks per minute that can be emitted by the ignition
 system.

Problem **The RPM readout is unstable**
Cause The LT connection on the RPM Box may be faulty
Action Inspect the wiring on the LT connections and repair, if necessary.

Problem **The RPM readout is unstable**
Cause The polarity of the LT connection may be wrong. There are normally three connections on the coil: HT, supply and trigger. The trigger can either be switched to ground or switched to +12V.
Action Connect the RPM Box in line with the other low tension side of the coil (e.g. supply or trigger). This will reverse the polarity of the signal going through the box.

Speed

Problem **The speed reading doesn't work at all**
Cause If it has never worked, the wheel speed sensor may need adjusting
Action The sensor must be set within 0.4 to 0.8 mm from the triggers on the wheel.

WARNING: DO NOT OVERTIGHTEN THE LOCKNUTS ON THE WHEELSPEED SENSOR – it will break. The maximum torque is 4Nm. Nip the lock nuts up with a spanner. You are advised not to use a socket set.

IMPORTANT: Although the wheelspeed sensor may appear to work at low speeds, unless the sensor is set within 0.4 and 0.8 mm, the sensor may not work at high speed.

Problem **The wheelspeed sensor has been adjusted but it won't work**
Cause Faulty sensor
Action Visually inspect the wheelspeed sensor for any damage to the head (too close to trigger) or body (over-tightened). Replace if necessary.

Cause	Faulty wiring
Action	See the 'Installation Notes' section for details on how to check the wiring for damage.

Problem The wheelspeed is wrong (e.g. by a factor of 2 or 4)

Cause	The sensor is not picking up all the triggers on the wheel
Action	Check that all the triggers are set within 0.4 and 0.8mm from the sensor.

Note: Because of the tolerance on the suspension of some saloon cars, it is very hard to set up multiple targets within 0.5 mm. In this case, it is best to use a single trigger.

Cause	The wheelspeed Pulse setting is wrong
Action	Check and adjust the value in Setup mode.

Problem The wheelspeed reading seems inaccurate (e.g. by 5 percent)

Cause	The Tyre diameter setting is wrong
Action	Check and adjust the value in Setup mode. This should be the actual rolling diameter of the tyre when it is under load.

Using an ABS speed sensor...

Problem The wheelspeed appears incorrect when using an ABS sensor interface box

Cause	The number of triggers and/or the tyre diameter set in the dash may be wrong
Action	Check the number of triggers on the ABS sensor wheel and set up the dash

Cause	The ABS interface box is earthing to the chassis
Action	Do not connect any of the wires from the interface box directly to the chassis

Cause	The ABS sensor is also trying to drive the car's ABS system
Action	Isolate the interface box wiring from the ABS system with 100 μ F capacitors as described in the 'Installation Notes' section.

Using the waterspeed sensor...

Problem The water speed appears incorrect

Cause The number of triggers and/or the tyre diameter settings in the dash may not be providing a correct calibration with the boat speed

Action Adjust the value used for tyre size to change the speed displayed by the dash (try 650mm and 20 pulses per rev). The speed can be calibrated against a hand-held GPS unit.

Problem The waterspeed trace is very 'noisy' even when the boat is in smooth water

Cause The sensor may have been mounted on the hull in such a way that it picks up turbulence from the prop or fins on the hull

Action Try mounting the sensor in a different position on the hull as indicated in the installation section

Cause The sensor may be mounted too high on the hull and is being driven by the air flow under the hull

Action Move the sensor lower on the hull.

Using the wheelspeed selector box...

Problem The speed information is corrupted

Cause The wheelspeed selector box is picking up noise from the chassis

Action Do not connect the supply 0V (Pin G on the selector box) if the ABS sensors are earthed to the chassis

Cause The power supply is being taken directly from the battery

Action The 12V supply (Pin J on the selector box) should come from the X Sport and not directly from the vehicle battery

Lap times (beacon)

If you have not purchased a beacon receiver for your X Sport, the dash cannot show lap times.

To test the beacon system, turn on the X Sport and beacon transmitter and wave the beacon transmitter in front of the receiver on the car. The lap times on the X Sport should change.

Problem **Lap times don't appear on the dash**

Cause The X Sport must be configured to use a beacon

Action Check and adjust the setting in Setup mode.

Problem **Lap times aren't working (dash shows 0.00)**

Cause The beacon transmitter isn't being powered; the LED on the beacon transmitter isn't on

Action Make sure the battery wiring is secure, and that the battery is fully charged (12V).

Note: Although a lit LED on the transmitter indicates a good connection to the battery, only a fully recharged battery will supply a strong signal to the car. Make sure you recharge the battery before a day at the track.

Cause The channels are not correctly set

Action Make sure that the beacon transmitter (on the pit wall) and receiver on the car are set to the same channel. They both have a switch with positions 0 to 9

Cause The transmitter and receiver are not lined up correctly

Action As the car passes the transmitter, make sure that there is a clear line-of-sight between the two.

Cause Sunlight is dazzling the receiver

Action The sun – a large infrared beacon transmitter! – should not shine into the receiver as it passes the pits. Place the receiver on the other side of the car and move the transmitter to the other side of the track.

Problem **Lap times are being corrupted**
Cause If the wheelspeed sensor is not set up properly, the dash will occasionally read zero road speed and insert pit stops in its data. This shows up with very short lap times (e.g. 2 seconds).
Action Check and adjust the wheelspeed sensor (see section on wheel speed troubleshooting).

Problem **The lap times seem wrong**
Cause The car may be picking up someone else's beacon signal.
Action Check if any other teams are running with the same type of beacon transmitter on the same channel and agree to use different channels.

Temperatures

When measuring temperatures with a thermocouple ...

Problem **The thermocouple readings are noisy**

Cause The thermocouple amplifier box is picking up electrical noise from the chassis

Action Make sure the thermocouple amplifier box is not electrically connected to the chassis.

Cause The amplifier is picking up electrical noise from the chassis

Action Make sure the leads for the thermocouple probe and amplifier do not pass close to high voltage sources such as the ignition coil or magneto.

Pressures

Problem	The pressure readings are wrong
Cause	The pressure sensor is faulty
Action	Check that the connectors on the pressure sensors are correctly fitted, and going to the right sensor. If necessary, change the pressure sensor.
Cause	The pressure sensor wiring is damaged
Action	Check the wiring on the car for visible damage and repair where necessary.

Note: If one pressure sensor seems wrong, try putting its connector onto the other sensor. If the fault moves with the connector, then the wiring or dash is faulty. If the fault does not move with the connector, the pressure sensor needs replacing.

When using the turbo/carburettor pressure sensor...

Problem	The X Sport appears to display the wrong turbo or carburettor pressure
Cause	The X Sport and pressure sensor may be incompatible
Action	If you are using the low range pressure sensor (0 to 2.5 bar) the pressure channel units must be configured as tbar under the UNITS menu in setup mode.

Telltale

Problem	The dash won't go into Telltale mode
Cause	The dash cannot go into Telltale mode until the car has been driven and then stopped.
Action	Drive the car.



Appendices

Appendix A - Using the Outing Report Manager (ORM) software

Introduction

When used in the Standalone mode (SA) the X Sport collects telltale data. This telltale data can then be offloaded via a serial COM port. If your PC does not have a serial COM port you can use a USB to Serial adapter. Pi Research can supply such an adapter kit, part number 30K-162200.

The Outing Report Manager (ORM) converts this telltale data into an Outings Report. The ORM application allows Club racers to view, save, recall and compare these Outing Reports.

Operating system

The ORM will run under Windows 2000™ or Windows XP™ operating system.

Software installation

To run the software you must first install it on the hard drive of your computer (normally called the C: drive). The ORM Software is supplied on a CD-ROM.

To install the ORM Software:

- 1 Power up the PC.
- 2 Insert the CD-ROM containing the ORM Software into the CD drive.
- 3 Follow the instructions on screen.

The ORM files will be copied from the CD-ROM onto your computer.

Starting the ORM application for the first time

In Stand Alone mode, the telltales data for all the laps and channels are transmitted from the from the X Sport when the outing comes to an end. This data is transmitted every 10 seconds until a power cycle or the next outing commences. If a channel is not used it will still be sent.

After you have installed the software on your PC you must start the ORM application for the first time. During the first time it is run the software creates a download path for the telltales data and lets you choose which COM port you will use to download this data.

Note: The Download Wizard will not start if it cannot detect telltales data on the X Sport. You should collect telltales in the X Sport before you run the ROM software for the first time.

To start the ORM application for the first time:

- 1 Click **Start** on the Windows Taskbar and choose **Programs** ▶ **piXpress** ▶ **ORM**. The Download Wizard Welcome Screen appears.



ORM Download Wizard - Welcome screen

- 2 Click **Next** to continue or **Cancel** if you don't want to offload now
- 3 If you clicked **Next** the Wizard will show the COM ports available..

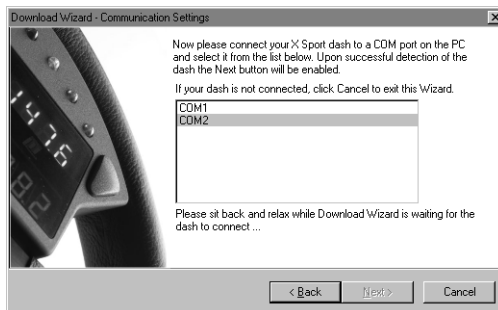

ORM Download Wizard - Communication Settings page

4 Choose the COM port which you will use to connect the X Port download loom.

After you have selected a COM port the application waits for a connection from the X Sport. If the X Sport has telltales data stored, it transmits a databurst every 10 seconds.

5 Connect the PC to the download port on the X Sport loom.

If the connection is good the Wizard downloads the data from the X Sport. The Next button is not enabled until a COM port is selected and a valid message from the X Sport is detected on that COM port.

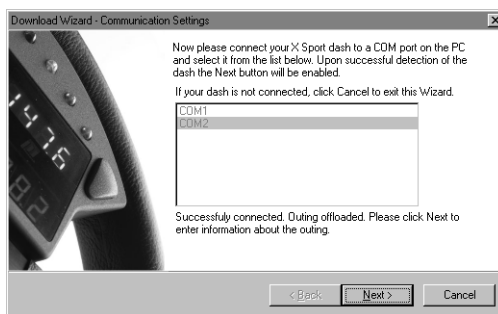

ORM Download Wizard - Connected page

If the Wizard does not detect data from the X Sport, the **Next** button is replaced by the **Finish** button. The **Cancel** button will disappear. If this happens check the connections. Also check tat you have connected the download lead to the COM port specified in the Wizard.

6 Click **Next**.

The Wizard changes to show the Venue page.

- 7 You must now enter **Venue** and **Driver** details. You can also enter comments in the Comments text field. You can change these comments later.

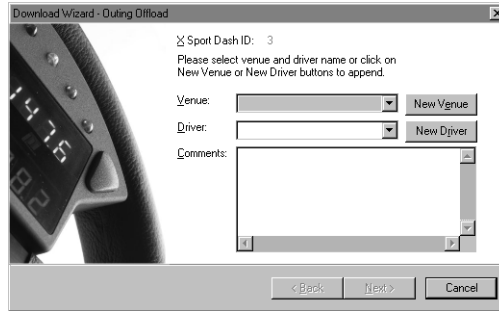

ORM Download Wizard - Venues page

- 8 After entering the details click Next. The Wizard changes to display the Congratulations page.

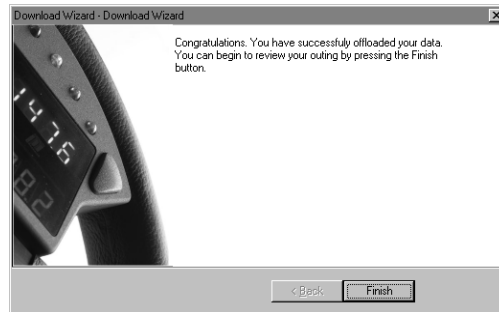

ORM Download Wizard - Congratulations page

ORM download path

Each offloaded outing is stored on the PC in separate file. The ORM storage directory *Pi ORM* is created in a sub-directory in the Shared Documents directory:

C:\Documents and Settings\All Users\Documents.

This storage path is created the first time the software is run.

Within the Pi ORM directory, a subdirectory is created for each Venue when the telldata is offloaded. In turn, each Venue contains a subdirectory for each Driver. This is illustrated in the next figure.

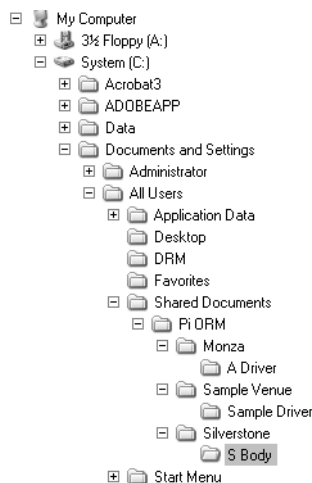

ORM Download path

Outing file format

Each outing file name is constructed as follows:

Venue_DriverName_DateYYMMDD_TimeHHMM.XPT

E.g.: PalmerSport_Brian_040104_1713.XPT

To prevent saving duplicate outings, the X Sport Outing Report Manager stores information on every downloaded outing for every X Sport number.

Outing Report

After the download has completed the main ORM window appears, displaying an Outings Report using the data just downloaded.

Lap	Time [m:s.ms]	Speed [mph]		RPM	Oil T [C]	Oil P [PSI]	Coolant T [C]	Fuel P [PSI]
		Min	Max	Max	Max	Min	Max	Min
Out	00:28.454	40	138	6844	65	59	72	47
2	00:24.748	45	138	7003	77	42	75	46
In	00:31.692	46	137	7130	82	54	77	47

X Sport Outing Report Manager main window

The units for speed, temp and pressure will be specified in the offloaded data, and are shown in the table column headers near the respective captions.

Sorting data

To sort the data in the Outing Report click on the caption in a column to sort the rows in ascending or descending order. An arrow sign next to the column caption indicates which column is sorted and in which direction.

RPM	Coolant T [C]
Max ←	Max

RPM	Coolant T [C]
Max →	Max

Arrow sort indicators

If columns have an equal first column criteria, then a second order will be applied. In Compare Outings mode this is the date and time of the Outing. In Single Outing mode it is Lap Number.

ORM operating modes

The ORM can operate in **Single Outing** mode or **Compare Outings** mode.

Single Outing mode

While in Single Outing mode, you can look at only one outing at a time. To change the displayed outing you use the **Open Outing** button or press **o** on the keyboard to display an Open dialog, which allows you to find the new Outing to display.

Each new offloaded outing will replace the currently displayed outing.

Compare Outings mode

While in Compare Outings mode, you can look at several Outings at once. The Outings are represented by their **Fastest Lap**, which will occupy one row each.

After the telltales data has been downloaded you can use the ORM to compare Outings.

A sample telltales data set is installed in the X Sport ORM default data folder under the name **Sample Outing**.

To Open an Outing:

- 1 Click **Start** on the Taskbar and choose **Programs > piXpress > ORM**. The ORM main window appears.

The window displays the last Outing Report used.

- 2 To open an outing click **Open Outing** on the menu ORM menu bar (Or press **O** on the keyboard). The Open dialog appears.

The Open dialog is set to the last folder location from which a file was opened. The first time it is opened it is set to the sample data set.



Open dialog

- 3 Use the Open dialog to locate the Outing file.

You can use the ORM to compare Outings. The Compare Outings mode and Single Outing mode are controlled by the same button which toggles between the two modes when clicked. You can also toggle between the modes using the t key on the keyboard.

To Compare Outings:

- 1 Click **Compare Outings**.
- 2 Open the all outings that you want to compare.

The ORM main window displays the telltales data for the Fastest Lap in each Outing.

Venue	Driver	Dash	Date	Time	Fastest Lap	Lap Time [mcs.ms]	Speed [kph]		RPM	
							Min	Max	Max	
Caxton	AE Newman	1	28/01/2004	12:24:46	3	0:28.490	46	46	466	
Caxton	AE Newman	1	28/01/2004	12:19:16	6	0:28.205	46	46	466	
Silverstone	Any Driver	1	28/01/2004	12:06:46	2	0:20.370	46	46	466	
Budby	A Driver	3	26/01/2004	16:32:31	2	0:1.190	0	0	487	
Anywhere	S Body	3	26/01/2004	16:43:59	6	0:10.200	28	28	298	

ORM main window in Compare Outings mode

You can remove an Outing from the ORM main window in Compare Mode.

To remove an outing from the ORM main window:

- 1 Click the symbol in the last column of the Outing you want to remove from the window.

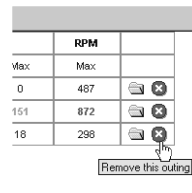

Remove an Outing

You can replace an Outing in the ORM main window in Compare Mode.

To replace an outing from the ORM main window:

- 1 Click the  symbol in the last column of the Outing you want to remove from the window.



Replace an Outing

The Open dialog appears. Use the Open dialog to find the outing you want.

You can switch between Compare Outings mode and Single Outing mode.

To switch between Compare Outings mode and Single Outing mode:

- 1 Double click in the row of the Outing you want to see. The selected Outing Report is shown in the ORM main window.

OR

Click in the row of the Outing you want to see and click **Single Outing**. The selected **Outing Report** is shown in the main window. The text on the button changes to read **Compare Outings**.

You can edit the comments in the current Outing Report. The Edit Comments button is enabled only in Single Outing mode and the current dataset is not **Read Only**.

To Edit Comments:

- 1 Click Edit Comments. The Outing Offload dialog appears.



Outing Offload dialog

The **New Venue** and **New Driver** buttons are disabled.

- 2 Make the changes to the comments as required.
- 3 Click **OK**.

The information is saved back to the outing dataset and the display is refreshed.

Options

You can change certain properties in the current Outings Report using the Properties dialog. The properties which you can change depend upon the mode you are in.

To open the Properties dialog:

- 1 With an Outing Report open in Single Outing mode, click **Options**. The Properties dialog page appears.

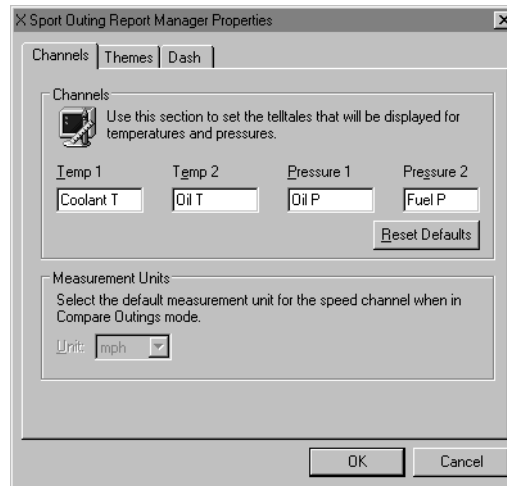

Properties dialog

Channels page

The Channels page contains four edit boxes for labelling the 4 columns (**Temp 1**, **Temp 2**, **Pressure 1** and **Pressure 2**) in **Single Outing** mode. The input fields are limited to 20 characters per field.

The page has a **Reset** button to reset the values to the default ones. The values that you enter in this page will be saved with the Outing.

Measurement Units option

The Measurement Units option (kph or mph) is disabled in Single Outing mode, but is available if you clicked **Options** whilst in Compare Outings mode. You can change the default speed measurement unit used in Compare Outings mode (as they can be different for the different outings). Outings recorded in different measure unit than the selected one will be converted for display purposes only and will remain with their actual values in the offload file.

Themes page

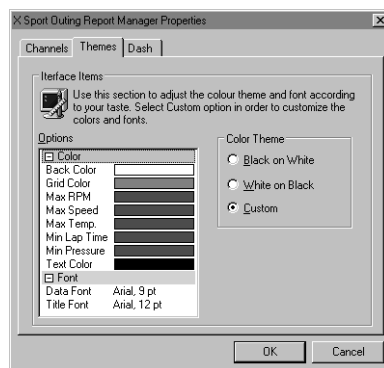

Themes Page

This page allows you to customize to colours of application. You can choose between **Black on White**, **White on Black** or **Custom** theme.

If the **Black on White** or **White on Black** theme is selected you will not be able to customize the colours and the font and they will be disabled and greyed out.

Dash page

This page contains various X Sport and communication options.

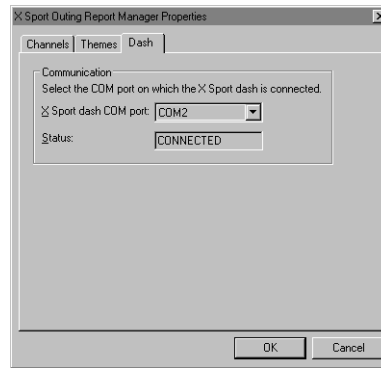

Dash page

The combo box shows the available COM ports on the computer. If the you never completed the Download Wizard the combo box will be blank. If there are no COM ports a message will be displayed on the page stating No COM ports have been found on this computer.

Read only outings

The application supports opening read only outings. In this case a message is displayed stating that you are opening a **read-only** outing and will not be able to make any changes to it. This message will popup only if in Single Outing mode as in Compare Outings mode changes in the outings cannot be made.

In this case the Edit Comments command from the toolbar is disabled. In addition the four edit fields in the Channels page will be disabled in the Options dialog.

Offload Outings

CAUTION: Do not remove the power from the X Sport at the end of an outing if you are going to offload the Telltales data. Removing power will delete the stored Telltales data.

The ORM gives you a choice in the way you offload the telltales data:

- You can choose to open the Download wizard.
- Automatic offload - the ORM detects when an X Sport has been connected to the PC and opens the Offload dialog

The use of the Download Wizard is covered in the section *Starting the ORM application for the first time*

To open the Download Wizard:

- 1 Click on the down arrow on the **Open Outing** button. A pop-up menu appears.

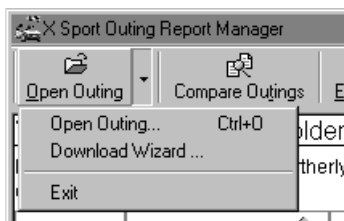

Pop-up menu

- 2 Click **Download Wizard....**The Download Wizard appears.
- 3 The Download Wizard will guide you through the download procedures.

Refer to the following section to use the automatic offload function.

Automatic offload of an Outing:

- 1 With the ORM application running on the PC connect the download lead to the download connector on the X Sport loom.

While the ORM is running it will constantly listen for X Sport packets at the appropriate COM port. When the X Sport has telltales data stored it sends a data burst every ten seconds on the down load connector.

Once a data burst has successfully been received, the ORM compares it to the existing outings, and will either ignore it (if the outing has already been offloaded) or open the **Outing Offload** dialog.

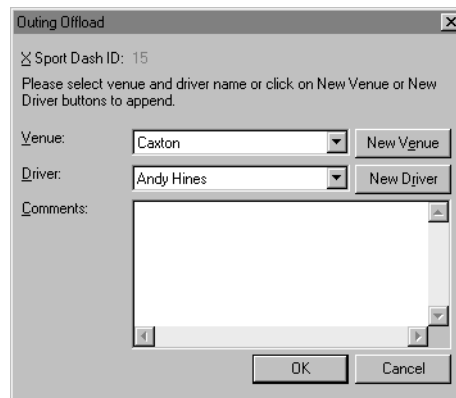

Outing Offload dialog

The Outing Offload dialog displays the **Venue** name and **Driver** name of the previous download. You can accept these names or click the appropriate  to choose a different **Venue** or **Driver** from the list shown.

The Driver names listed are associated with the respective X Sport dash number. If for a particular X Sport this is the very first time a data is downloaded, the Venue and Driver boxes are disabled, and will state **Use the New buttons to define entries**.

New Venue and New Name

If none of these previous names are appropriate, click **New Venue** or **New Driver** and an appropriate dialog will appear to allow you to enter the respective name.



New Venue dialog

- 2 Use the **Comments** field of the Outing Offload dialog to comment on the Outing. The comments can be changed later.
- 3 When you have finished click **OK** on the Outing Offload dialog.

A new file will be constructed in the Outings Storage directory, and the current time and date will be appended to its contents. In the case where no Venue and/or Driver have been selected (if for particular X Sport, this is the first time a data is received), the **OK** button will be disabled.

Copy to the clipboard

ORM allows you to copy the contents of the main window into tab-separated values, which can then be pasted into Microsoft Excel™ or similar.

To copy and paste the contents of the main window:

- 1 Press **Ctrl+C** on the keyboard. The ORM will copy the header, description (if in Single Outing mode) and the entire contents of the grid.
- 2 To paste the contents of the clipboard into a Microsoft Excel™ document (or similar) press **Ctrl+V** on the keyboard.

Printing

The X Sport ORM does not support printing. Instead, use **Copy and Paste** into an application that will handle text and then print the document into which the data was pasted.

Serial connection

ORM uses only COM ports to connect to the X Sport. The chosen COM port is configured automatically by the ORM, using the values listed below.

Parameter	Value
Bits per second	38400
Data bits	8
Parity	None
Stop bits	1
Flow Control	None

Many new computers are not equipped with Serial COM ports which are required by the ORM to download the telltales data, but most new computers have USB ports.

piXpress can supply a USB to serial adapter kit, part number 30K-162200.

The USB to Serial adapter is used to connect the download connector on the loom of the X Sport to a USB equipped Windows™ computer.

The USB to Serial adapter has a standard DB 9 pin male serial port connector at one end and a standard Type A USB plug connector on the other end. You attach the download loom connector onto the serial port of the adapter, and plug the USB connector into a USB port on your PC.

The USB to Serial adapter will work on all Windows™ operating systems.

Appendix B - Fitting an un-terminated loom

Use this appendix for information on fitting an un-terminated loom.

Un-terminated loom details

X Sport. The loom also has the ORM Download connector fitted.

The wires for each of the sensors are grouped, colour coded and tagged with their identity. You must terminate these wires with the correct connector.

Connect the loom to the X Sport

Plug the AutoSport connector into the connector on the rear of the X Sport.

Lay the loom in the car

Run the wires to each of the sensors on the car. Take care to avoid sharp metal edges and cables carrying high voltages (e.g. ignition circuits).

System supply

You may need to untwist the power and ground supply wires if the battery is at the front of the vehicle (connect red wire from loom) and the Master switch is towards the rear (connect black wire from loom).

Beacon

Run the beacon connections to a suitable position (e.g. by the roll hoop), even if you do not yet have a beacon receiver.

Secure unwanted sensor wires

Isolate any wires you are not using near the X Sport and insulate the ends with tape. Keep the sleeve and wire idents on the loom to facilitate identification at a later date.

Cut the Loom to size

Now that the loom is lying in the car, you can determine how long each group needs to be. Before cutting the wires, the loom should be consolidated by grouping sensor wires together and taking branches where particular sensors require it.

You should use tape at each branch point to hold the loom in shape.

The individual sensor groups are now ready to be cut to length. Use tape to mark the length required, untwist the wires and slide the ident sleeve AND individual wire idents to the marked point. Be sure to leave enough length so that connections are not under stress.

Cut the branches to length and tie the loose ends to prevent the idents sliding off. Cut all the wires to the same length for each sensor.

Fit the connectors. In most cases, you can do this more easily if you remove the loom from the car.

Fit SureSeal connectors to the loom

The Oil temperature, Coolant temperature, RPM, Wheelspeed, and beacon sensors are supplied terminated with 2-pin or 3-pin Cannon SureSeal connectors. You must fit the respective connector to the sensor loom. The sensor loom is then connected to the X Sport via a the AutoSport connector. The connections for each sensor wire are given in the tables below.

Note: On the loom, pin 1 is always a socket and pins 2 and 3 are always pin contacts.

2-pin Cannon SureSeal

Function	Pin1 (socket)	Pin2 (pin)
Oil temperature	Yellow	Red
Coolant temperature	Blue	Red

3-pin Cannon SureSeal

Function	Pin1 (socket)	Pin2 (pin)	Pin3 (pin)
RPM Black	Violet	Red	
Wheelspeed	Black	White	Red
Beacon	Black	Green	Red

Crimping a contact onto each wire

Take one wire (for example, the yellow wire for the Oil Temperature):

- 1 Strip approximately 8mm of insulation off the wire, taking care not to cut the wire itself.
- 2 Twist the strands of wire together.
- 3 Fold the stripped portion of the wire in half to form a tight loop.
- 4 Take a contact (socket for yellow wire) from the plastic bag and place it in aperture 3 of the crimp tool provided.

The two smaller clamping prongs should be facing the 'W' shaped part of the tool.

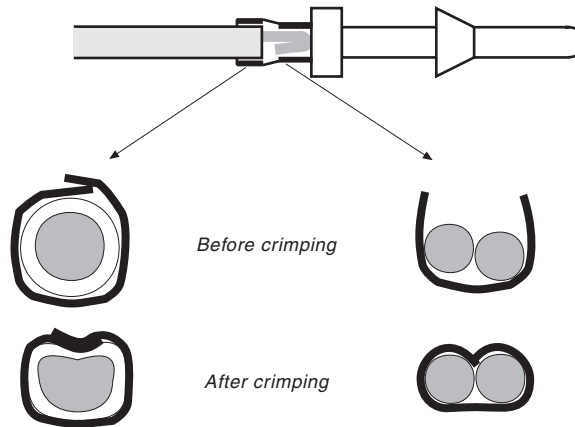

Waterproof connector crimp connections

- 5 Push the looped end of the wire right into the contact and crimp it by squeezing the handles all the way together.
- 6 Fold in the cable grip wings one at a time.

Use the flat front end section of the crimp tool (or a small pair of pliers) to fold in the cable grip wings one at a time, to hold the cable insulation.

- 7 Crimp the cable grip wings.

Finally, using aperture 3 of the crimp tool, crimp the cable grip wings so that they actually grip the insulation on the wire.

- 8 Repeat this process to crimp a pin contact onto the red wire for the oil temperature connector.

Insert the contact into the connector

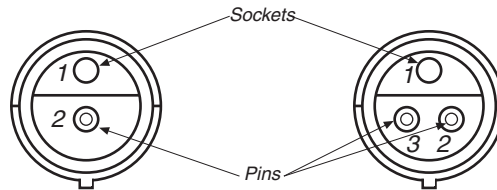

Cannon SureSeal connectors viewed from rear

- 1 Take one of the rubber 2-way connectors from the bag, and locate the contact insertion tool provided.
- 2 Slide the slot in the tool over the yellow wire (for example) and push the tool up to the neck on the contact.
- 3 Pick up the connector and push the contact firmly into hole 1 in the body until it is flush with the mating face on the inside of the connector.
- 4 Check that the contact is correctly located in the body then withdraw the tool.
- 5 Repeat this process for the red wire, pushing it into hole 2 on the connector.

Waterproof the SureSeal connectors

The SureSeal connectors must be fully waterproofed. This is done by sealing the rear of the loom connectors with the silicone sealer provided to stop water penetration. Once applied, leave the silicone to cure for one hour.

WARNING: Failure to waterproof the multiway connectors will not damage your X Sport but certain readings can be affected by water.

Repeat the process for each sensor

After the Oil temperature sensor has been connected, repeat the entire crimping and insertion process for the:

- Coolant temperature sensor
- RPM sensor
- Wheelspeed sensor
- Beacon receiver

WARNING: Failure to terminate any of the wires could lead to a short circuit of the X Sport.

Fit the spade connectors

Use spade connectors for 0—40 psi and 0—120 psi pressure sensors.

Unpolarised blade connections

Oil pressure	Black	Green
Fuel pressure	Black	White

- 1 Once cut to length, strip about 5mm of insulation off each wire. DO NOT LOOP the wire.
- 2 Take a spade connector and grip it gently in the crimp tool. Slide the wire into the connector until it hits the small stop.
- 3 Squeeze the tool to crimp the connector, making sure that the bare wire is crimped securely.
- 4 Repeat this process for the remaining wires.

Fit the 4mm ring tags

Use the 4mm ring tags for 0—200 psi pressure sensors.

Unpolarised 4mm ring tags

Oil pressure	Black	Green
Fuel pressure	Black	White

Repeat the procedure for the spade connectors detailed above.

Use the knurled finger nut and split washer to secure the ring tag to the sensor.

Note: Ensure that the split washer is between the ring tag and the knurled finger nut.

Reinstall the loom

- 1 Connect the X Sport, sensors and the power connections to the loom.

Check the installation

Before turning the X Sport on, check:

- the clearance on the wheelspeed sensor
- the freedom of wires from moving parts
- the connectors on the back of the X Sport
- the silicone sealant on the connectors
- no wires have been left un-terminated.

Appendix C - X Sport ECU loom information

Use this appendix for information on Loom part number 31L-0018. This loom is 3 metres long, for use with an ECU and is supplied terminated as shown in the next figure.

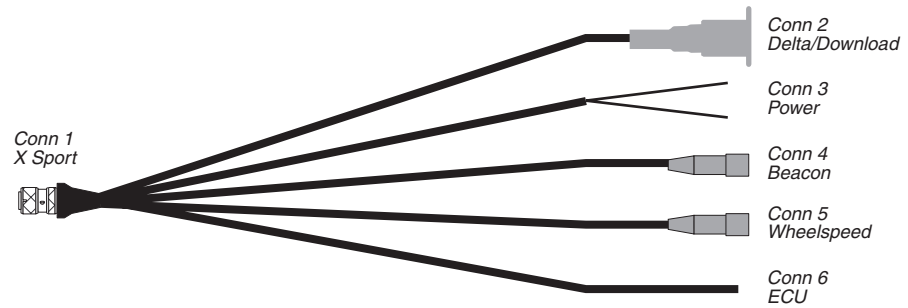

X Sport ECU loom

Pinout information is given in the next table.

X Sport ECU loom connector pinout information

Conn1 details

Connector type: AS6-12-35SN Label: X Sport

Pin	Function	Dest1	Dest2	Comment
1	No connection			
2	No connection			
3	No connection			
4	No connection			
5	No connection			
6	No connection			
7	ECU data in to X Sport	Conn6-1		Can be from GPS
8	Dash TX	Conn2-4		
9	Main Ground	Conn3-2	Conn2-10	
10	Main +12V	Conn3-1	Conn2-8	
11	No connection			
12	No connection			
13	No connection			
14	No connection			
15	Beacon Signal	Conn4-2	Conn2-6	
16	Beacon Power	Conn4-3		
17	Wheelspeed Ground	Conn5-1		
18	Wheelspeed Signal	Conn5-2	Conn2-5	
19	Wheelspeed Power	Conn5-3		
20	No connection			
21	Beacon Ground	Conn4-1	Conn2-12	
22	No connection			
Screen	Connect overall screen			

X Sport ECU loom pinout information

Conn 2**Connector type: Deutsch 12-pin IMC 26 221 2X, sockets. Label: Download/Delta**

Pin	Destination - pin	Function
2-1	No connection	
2-2	No connection	
2-3	No connection	
2-4	Conn 1 - pin 8	Data from the X Sport
2-5	Conn 1 - pin 18	Speed signal
2-6	Conn 1 - pin 15	Beacon signal
2-7	No connection	
2-8	Conn 1 - pin 10	12V
2-9	No connection	
2-10	Conn 1 - pin 9	Data ground
2-11	No connection	
2-12	Conn 1 - pin 21	Beacon ground
Screen	Not required	

Conn 3**Connector type: Bare ends. Label: Power**

Pin	Destination - pin	Function
Red wire	Conn 1 - pin 10	+12V
Black wire	Conn 1 - pin 9	Ground
Screen	Not required	

Conn 4

Connector type: *Socket 3 way SureSeal. Label: Beacon*

Pin	Destination - pin	Function
4-1	Conn 1 - pin 21	Beacon Ground
4-2	Conn 1 - pin 15	Beacon signal
4-3	Conn 1 - pin 16	+12 Volts for beacon power
Screen	Not required	

Conn 5

Connector type: *Socket 3 way SureSeal. Label: Speed*

Pin	Destination - pin	Function
5-1	Conn 1 - pin 17	Wheelspeed Ground
5-2	Conn 1 - pin 18	Wheelspeed signal
5-3	Conn 1 - pin 19	+12 Volts for Wheelspeed power
Screen	Not required	

Conn6

Connector type: *Bare wire Label: ECU*

Pin	Destination - pin	Function
6-1	Conn 1 - pin 7	Data from ECU
Screen	Not required	

Appendix D - X Sport and MBE ECU

Introduction

The X Sport can display the following channels from an MBE ECU:

- Oil pressure
- Fuel pressure
- RPM
- Water temperature
- Oil temperature

External sensors required

The data stream from the ECU does not include Speed information. To enable speed to be displayed a wheelspeed input to X Sport is required. To provide lap times a beacon input to the X Sport is required.

X Sport setup for use with MBE ECU

The **Units** setup for oil and water temperatures are fixed at °C. The **Units** setup for fuel and oil pressure are fixed at PSI.

Set up **Alarms, beacon, RPM, Wheelspeed** and **Options** as required. The **Options -Type** must be set to *MBE* (MBE).

X Sport display fields used with an MBE ECU

When used with an MBE ECU the display fields used are shown below.

Realtime A	Realtime B	Race	Telltales C	Telltales D	Telltales E
Field 1 Lap number	Lap number	Lap number	Lap number	Lap number	Lap number
Field 2 Letter A*	Letter B*	Letter r*	Letter C	Letter D	Letter E
Field 3 Oil Press	Fuel press	Speed max**	Max speed	Min Oil press	Min Fuel press
Field 4 RPM	Battery volts	Lap time***	Lap time	Max RPM	Min battery V
Field 5 Cool temp	Oil temp	Speed min latched	Min speed	Max cool temp	Max oil temp

Page options: *Letter is replaced after 2 seconds delay by the gear number if you have setup gear numbers.

** Speed max can be Speed live.

***Lap time if you use a beacon, RPM if you do not.

X Sport ECU loom

The X Sport ECU loom for use with an ECU is supplied terminated. Refer to *Appendix C* for information on this loom.

Appendix E - X Sport and Pectel T6 2000, T6M and T2 ECUs

Introduction

Pectel ECUs T6 2000, T6M and T2 can be configured to output a DELTA_STREAM. The X Sport can be used to display the data in this stream.

Pectel T6 2000 and T6M channels:

The X Sport will display the following T6 2000 and T6M channels from the DELTA_STREAM:

- Speed (see Note below)
- Oil pressure
- Fuel pressure
- RPM
- Gear number
- Coolant temperature
- Oil temperature
- Lap times

*Note: If the T6 has a wheelspeed sensor connected to it, Speed can be included in the DELTA_STREAM and then displayed on the X Sport. However in the case where a wheelspeed sensor is NOT connected to the ECU one **MUST** be connected to the X Sport itself.*

External sensors required

The X Sport must have a beacon input to provide lap times.

Units displayed on X Sport can be changed via the **UNITS** menu on the X Sport.

Pectel T2 channels:

The X Sport will display the following T2 channels from the DELTA_STREAM:

- RPM
- Coolant temp
- Oil temp
- Oil pressure
- Fuel pressure

External sensors required

To provide lap times, a beacon input to the X Sport is required.

To display Speed, a wheelspeed sensor input to the X Sport is required.

Units displayed on X Sport can be changed via the **UNITS** menu on X Sport.

X Sport setup for use with Pectel ECU

Set up **Alarms, Beacon, RPM, Wheelspeed** and **Options** as required. The **Options - Type** must be set to *PECTEL* (Pectel).

Note: When setting the RPM you do not need to set the Pulses option.

X Sport display fields used with a Pectel ECU

When used with a Pectel ECU the display fields used are shown below.

Realtime A	Realtime B	Race	Telltales C	Telltales D	Telltales E
Field 1 Lap number	Lap number	Lap number	Lap number	Lap number	Lap number
Field 2 Letter A*	Letter B*	Letter r*	Letter C	Letter D	Letter E
Field 3 Oil Press	Fuel press	Speed max**	Max speed	Min Oil press	Min Fuel press
Field 4 RPM	Battery volts	Lap time***	Lap time	Max RPM	Min battery V
Field 5 Cool temp	Oil temp	Speed min latched	Min speed	Max cool temp	Max oil temp

Page options: *Letter is replaced after a 2 second delay by the gear number if you have setup gear numbers.

** Speed max can be Speed live.

***Lap time if you use a beacon, RPM if you do not.

X Sport ECU loom

The X Sport ECU loom for use with an ECU is supplied terminated. Refer to *Appendix C* for information on this loom.



Appendix F - Using X Sport to display data from a Delta logger

Introduction

The X Sport can be setup to display the data stream from a Delta Clubman logger or a Delta Lite logger.

Choosing channels to be displayed

You use the Logger Management Software (LMS) to set up the channels to be displayed on the X Sport. The LMS must have a Profile that includes the X Sport dash. Refer to the LMS User Guide for information.

- 1 Start the LMS application.
- 2 When the LMS is running click the Setup tab, followed by the Dash tab.
- 3 Click the X Sport tab on the Dash page.

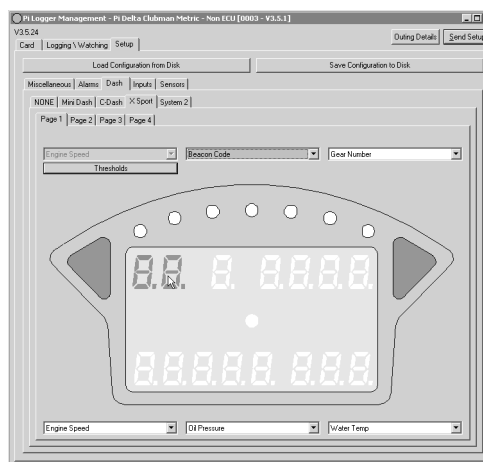

LMS X Sport Dash page

-
- 4 Configure the channels to be displayed on the X Sport fields.
 - 5 Complete the LMS setup and send the setup to the logger.

X Sport setup for use with a Delta logger

The X Sport Setup menu **Options -Type** must be set to *dE L T A* (Delta).

Some items within the X Sport Setup menus are not displayed when the X Sport is in Delta operating mode. Refer to section ***Menu items not displayed*** in this manual for details of these items.

Appendix G - Using X Sport to send data to a Delta logger

Introduction

In Standalone Mode the X Sport displays data from connected sensors. It also produces a data stream.

You use the Logger Management Software (LMS) to configure a Delta Clubman logger or a Delta Lite logger to log this data stream. You will need a Profile that will see the data stream from the X Sport as an ECU stream.

Id	Label	Name
2	Wheelspeed 1	FL Wheelspeed (FL W/S)
7	System Speed	Speed (Spd)
11	Lap Time	Lap Time (LTime)
12	Lap Number	Lap Number (LapNm)
36	Box Voltage	Box Voltage (BOXV)
37	Box Temperature	Box Temperature (BOXT)
38	GX	Inline G (Inlin)
39	GY	Lateral G (Accel)
41	Channel 1
42	Channel 2
43	Channel 3
44	Channel 4
45	Channel 5
46	Channel 6
76	Engine Rpm	Engine Rpm (Rpm)
77	Oil Pressure	Oil Pressure (Oil P)
78	Fuel Pressure	Fuel Pressure (Fuel P)
79	Coolant Temperature	Coolant Temperature (CoolT)
80	Oil Temperature	Oil Temperature (Oil T)
81	Gear Number	Gear Number (Gear)

Example of ECU channels in an LMS profile

Channels available

The channels available in the data stream will depend upon the sensors that are connected to the X Sport.

External sensors required

To provide lap times, a beacon input to the X Sport is required.

To display Speed, a wheelspeed sensor input to the X Sport is required.

Units displayed on X Sport can be changed via the **UNITS** menu on X Sport.

X Sport setup for use with a Delta logger

The **Options -Type** must be set to $\xi \bar{\mu}$ (Standalone).

X Sport display fields used with a Delta

When used with a Delta the display fields used are shown below.

Realtime A	Realtime B	Race	Telltals C	Telltals D	Telltals E
Field 1 Lap number	Lap number	Lap number	Lap number	Lap number	Lap number
Field 2 Letter A*	Letter B*	Letter r*	Letter C	Letter D	Letter E
Field 3 Oil Press	Fuel press	Speed max**	Max speed	Oil press	Fuel press
Field 4 RPM	Battery volts	Lap time***	Lap time	Max RPM	Min battery V
Field 5 Cool temp	Oil temp	Speed min latched	Min speed	Max cool temp	Max oil temp

Page options: *Letter is replaced after a 2 second delay by the gear number if you have setup gear numbers.

** Speed max can be Speed live.

***Lap time if you use a beacon, RPM if you do not.

X Sport ECU loom

The X Sport ECU loom for use with an ECU is supplied terminated. Refer to *Appendix C* for information on this loom.



Appendix H - X Sport and Rally P data stream

Introduction

The X Sport can be used to display the data in a Rally_P data-stream.

Rally P channels:

The X Sport will display the following channels from the Rally P data-stream:

- Oil pressure
- Gear number
- Speed
- RPM
- Water temperature
- Fuel pressure
- Batt V
- Oil temperature
- Speed/max
- Laptime

External sensors required

The X Sport must have a beacon input to provide lap times.

Units displayed on X Sport can be changed via the **UNITS** menu on the X Sport.

X Sport setup for use with Rally P

Set up **Alarms, Beacon, RPM, Wheelspeed** and **Options** as required. The **Options - Type** must be set to **RALLY P** (Rally P).

Note: The Menu item RPM> PULSES is not shown when the X Sport Type is set to RALLY P.

X Sport display fields used with the Rally P

When used with Rally P mode set the display fields used are shown below.

Realtime A	Realtime B	Race	Telltals C	Telltals D	Telltals E
Field 1 Oil Press	Speed	Oil press	Lap number	Lap number	Lap number
Field 2 Gear	Gear	Gear*	Letter C	Letter D	Letter E
Field 3 Speed	Fuel press	Speed	Max speed	Min Oil press	Min Fuel press
Field 4 RPM	Battery volts	Lap time***	Lap time	Max RPM	Min battery V
Field 5 Water temp	Oil temp	Water temp	Min speed	Max cool temp	Max oil temp

Page options: *Letter is replaced after a 2 second delay by the gear number if you have setup gear numbers.

***Lap time if you use a beacon, RPM if you do not.

X Sport ECU loom

The X Sport ECU loom for use with an ECU is supplied terminated. Refer to *Appendix C* for information on this loom.

Appendix J - X Sport and Interport unit

Introduction

The X Sport can be setup to display a data from a Pi Interport unit.

X Sport setup for use with an Interport unit

The X Sport menu **Options -Type** must be set to `INTERPT` (Interport).

Menu item changes

The Interport datastream is formatted as though it was coming from an ECU, therefore some parameters cannot be set in the X Sport. The following X Sport menu items are changed when **Options -Type - Interport** is selected.

Main menu	Sub menu	Comment
Units	SPEED	Not shown
	TEMP	Not shown
	FUELPRS	Not shown
	OILPRSS	Not shown
RPM		
	PULSES	Not shown
Wheelspeed		
	DIAMETR	Not shown
	TRIGGER	Not shown
Options		
	GPS ZONE	Shown when INTERPORT type is selected

Interport channels

The X Sport will display the following channels from the Interport data stream:

- Engine Speed (RPM)
- OBD Speed
- Oil pressure
- Boost pressure (if available)
- Oil temperature
- Water temperature
- Battery volts

Channels in the datastream which cannot be displayed but can be logged:

- Throttle position

GPS channels available (if the optional GPS unit is connected)

These channels are available in the data stream. They cannot be displayed on the X Sport, but can be logged.

- GPS speed
- Heading
- Lat
- Long
- Height
- Time
- Number of satellites seen

External sensors required

The Interport must have a beacon input to provide lap times.

The Units in which data are displayed on X Sport can be changed via the **UNITS** menu on the X Sport.

X Sport display fields used with an Interport unit

When used with an Interport the display fields used are shown below.

Realtime A	Realtime B	Race	Telltales C	Telltales D	Telltales E
Field 1 OBD Speed	OBD Speed	Lap number	Lap number	Lap number	Lap number
Field 2 Letter A*	Letter B*	Letter r*	Letter C	Letter D	Letter E
Field 3 Oil Press	Boost press**	Speed max***	Max speed	Min Oil press	Min Boost press
Field 4 RPM	Battery volts	Lap time****	Lap time	Max RPM	Min battery V
Field 5 Cool temp	Oil temp	Speed min latched	Min speed	Max cool temp	Max oil temp

Page options: * Letters **A**, **B** and **r** will be replaced after a 2 second delay by the gear number if you have set up gear numbers using the **Gear ratio display** facility of the X Sport.

** If boost pressure is available it will be displayed in this field.

*** Speed max can be Speed live.

****Lap time if you use a beacon, RPM if you do not.

Outings Report Manager (ORM)

ORM is not available when the X Sport is set to Interport mode.

Appendix K - X Sport 7-segment display to text glossary

This glossary lists the X Sport 7-segment displays and their meanings in text.

X Sport display	Meaning
ACCELO	Accelerometer
ALARMS	Alarms
AUTO	Auto
BAR	BAR
BATTERY	Battery
BEACON	Beacon
BOOST	Boost
BRIGHT	Bright
CONFIRM	Confirm
COOLTEMP	Coolant temperature
CQM	CQM (Club Qualifying Mode)
DEFAULT	Default
°C	Degrees Centigrade
°F	Degrees Fahrenheit
DELTA	Delta (Pi Delta logger)
DEMO	Demo
DIAMETER	Diameter
DONE	Done
DOWN	Down
ENABLED	Enabled
FILTER	Filter
FITTED	Fitted
FIX	Fix
FUELPRES	Fuel pressure
GEARS	Gears
GEARSCALIB	Gears calibration
GPS	GPS
GPSZONE	GPS zone

X Sport display	Meaning
INtPt	Interport
KGF	KGF
KPH	KPH
LAtCH	Latch
LAUNCH	Launch
LAUNCH St	Launch start
MASt	Mask
MBE	MBE ECU
MOde	Mode
MPH	MPH
NO	No
NO .GFS	Number of gears
ObdII	OBDII
OFF	Off
OIL PRSS	Oil pressure
OIL tEMP	Oil temperature
OPtIONS	Options
ORM	ORM (Outing Report Manager)
OUT SPd	Outing start speed
PECTEL	Pectel ECU
PSI	PSI
PULSES	Pulses
RALP	Rally P
REAL	Real
REDLINE	Redline
REDLINE St	Redline start
RESEt	Reset
RESEtTING tO dEFaultS	Resetting to defaults
RPM	RPM
Run	Run
SELFtSt	Selftest
SPEED	Speed
SA	SA (Stand Alone X Sport)
TBAR	TBAR

X Sport display	Meaning
TEMP	Temperature
TEST	Test
TIME	Time
TIMER	Timer
TRIGGERS	Triggers
TYPE	Type
UNITNO	Unit number
UNITS	Units
UP	Up
USER	User
WHEELSP	Wheelspeed
YES	Yes

Index

Index

Symbols

- 0 - 200 psi pressure sensors 167
- 2-pin SureSeal connector 163
- 3-pin SureSeal connector 163
- 4mm ring tags 167

A

- Accelerometer
 - input 49
 - Reset menu 51
- Adding a filter to your RPM or wheelspeed signals 64
- Alarms 74
 - alarm light 74
 - alarm message 74
 - alarm prevention 75
 - Race Mode 75
 - maximum coolant temperature 20, 74
 - maximum oil temperature 20, 74
 - minimum battery voltage 20, 74
 - minimum fuel or turbo pressure 20, 74
 - minimum oil or turbo pressure 20, 74
 - setting alarm thresholds 75
 - thresholds 74
 - Battery Voltage -0.5V 74
 - Pressures -5psi 74
 - Temperatures +5°C 74
- Alarms menu 44
- Auto-adjust 40
- Automatic ratio selection 61, 189

B

- battery 81
- Beacon mask 45
- Beacon menu 45
- Beacon receiver 21, 70
 - test 70
- Button functions 25

C

- Channels page (ORM) 154
- Checklists 70
- Club qualifying mode
 - Reset menu 51
- Club qualifying mode menu 45
- Compare Outings mode (ORM) 149
 - fastest lap 149
- coolant temperature sensor 100
- Crimping a contact 164

D

- Dash page (ORM) 156
- Default menu 50
- disable the Gear ratio display 65
- display fields 19
 - coolant temperature 19
 - fuel pressure 19
 - gear number 19
 - gear-change lights 19
 - lap times 19
 - oil pressure 19
 - oil temperature 19
 - page identification letter 19
- Race Page 23, 24, 174, 177, 189
- Realtime Page A 23, 24, 174, 177, 189
- Realtime Page B 23, 24, 174, 177, 189
- RPM 19
- RPM redline 19
- Speed 19
- Telltals 21
 - Telltals Page C 23, 24, 174, 177, 189
 - Telltals Page D 23, 24, 174, 177, 189
 - Telltals Page E 23, 24, 174, 177, 189
- Down timer 59
- Download dialog (ORM)
 - New Name 159
 - New Venue 159
- Driving the car 73

E

ECU loom connector 170
 Connector 2 171
 Connector 3 171
 Connector 4 172
 Connector 5 172
 Connector 6 172
elapsed stage times 21
Enable Club qualifying mode 52
Enable the GPS functions 56
End-of-lap marker 57
Entering setup mode 39
EOL marker 57

F

Fastest Lap 149
Fitting the X Sport 82
 in a vehicle dash 84
 torque settings 84
 on a steering wheel 83
 bracket 83
 torque settings 83
 X Sport dimensions 82
Fixed lap times 21

G

Gear number
 Reset menu 51
Gears menu 47
GPS lap number
 Reset menu 51
GPS zone 58

I

In-lap 77
Initial checks 69
Installation
 separate 12 volt battery 81

L

Lap counter 21
Lap number 20
 Reset menu 51
Lap time 20, 21
 telltales 21
Lap timing
 monster beacon transmitter 22
Launch 46
 Launch Start 46

M

Master switch 81
Maximum coolant temperature 20, 74
Maximum oil pressure 20
Maximum oil temperature 20, 74
Maximum RPM 20
Maximum speed 20
MBE ECU 173
Measurement Units option 155
Minimum battery volts 20, 74, 75
Minimum coolant temperature 20
Minimum Fuel or turbo pressure 74
Minimum fuel or turbo pressure 20
Minimum fuel pressure 20
Minimum oil or turbo pressure 20, 74
Minimum oil pressure 20
Minimum speed 20
Monster beacon transmitter 22
Mounting the temperature sensors
 oil and coolant temperature sensors 100

O

OBDII protocols scan
 Reset menu 51
oil and coolant temperature sensors 100
oil temperature sensor 100
Open an Outing (ORM) 150
Open dialog (ORM) 150
Operating mode 11
 Race mode 11
Operating system 143

- Options Dialog (ORM)
 - Dash page 156
 - Themes page 155
- Options menu 49
- ORM
 - automatic offload function 158
 - automatic offload of an Outing 158
 - Download path 147
 - Download Wizard
 - Communications settings 145
 - Congratulations page 146
 - Connected page 145
 - Venues page 146
 - Welcome screen 144
 - New Name dialog 159
 - New Venue dialog 159
 - Operating modes 149
 - Compare Outings mode 149
 - Single Outing mode 149
 - option 30, 77
 - remove an outing 151
 - Sample Outing 150
 - Software
 - to install the software 143
- Out-lap 77
- Outing file format 147
- Outing Offload dialog 158
- Outing Report 22, 148
 - Sorting data 148
- Outings Report Manager 22
 - Outing Report 22
- Outings Report Manager kit 22

P

- Pectel T2 ECU 176
 - channels 176
- Pectel T6 2000 and T6M channels 175
- Pectel T6 2000 ECU 175
- Pectel T6M ECU 175
- Power supply 81
 - battery 81
 - master switch 81

- Power-up mode 26
- Preparing for an outing 72
 - Alarms 74
 - Battery alarm 75
 - Lap Times 73
 - Powering up the X Sport 72
 - Race Page 73
 - Realtime Page A 72
 - Realtime Page B 72
 - Spinning off 73
 - Warming up the car 72
- Pressure measurement 97
- Properties dialog 154
 - Channels page 154
- Pulses 46

R

- Race mode 29
- Race Page 23, 24, 29, 174, 177, 189
 - Lap number 23, 24, 174, 177, 189
 - Latched maximum speed 23, 24, 174, 177, 189
 - Page ident letter r 23, 24, 174, 177, 182, 189
 - Realtime speed 23, 24, 174, 177, 189
- Realtime mode 27
- Realtime Page A 23, 24, 27, 174, 177, 189
 - coolant temperature 23, 24, 174, 177, 189
 - oil pressure 23, 24, 174, 177, 189
 - Page ident letter A 23, 24, 174, 177, 189
 - Realtime mode 27
 - RPM 23, 24, 174, 177, 189
 - Wheelspeed 23, 174, 177, 189
- Realtime Page B 23, 24, 28, 174, 177, 189
 - Fuel pressure 23, 24, 174, 177
 - Oil temperature 23, 24, 174, 177
 - Page ident letter B 23, 24, 174, 177, 189
 - Wheelspeed 24
- Redline 46
- Reset menu 51
 - Accelerometer 51
 - Club qualifying mode 51
 - Gear number 51
 - GPS lap number 51

- Lap number 51
- OBDII protocols scan 51
- Timer 51
- Using the Reset menu 51
- Resetting CQM stored lap data 55
- Returning to the pits 76
 - Inspecting telltales 76
 - Telltale mode 76
 - Telltale Page C 76
 - Lap number 76
 - Lap time 76
 - Maximum speed 76
 - Minimum speed 76
 - Telltale Page D
 - Lap number 76
 - Maximum coolant temperature 76
 - Maximum RPM 76
 - Minimum oil pressure 76
 - Telltale Page E
 - Lap number 77
 - Maximum oil temperature 77
 - Minimum battery voltage 77
 - Minimum fuel pressure 77
- Telltale Pages
 - Telltale data 77
- RPM box switch settings 95
- RPM input 11
- RPM measurement 88
 - digital tach signals 88
 - tachometer connections 89
 - tachometer signals 89
 - the RPM box 90
 - clean up a noisy tach input 89, 94
 - connections 90
 - connector 90
 - current pulses 90
 - example Setups 96
 - example Setups: 4-cylinder 4-stroke 96
 - example Setups: 4-cylinder 4-stroke with double co 96
 - example Setups:1-cylinder 2-stroke 96
 - HT connection 92

- LT connection 91
- mounting 90
- voltage pulses 90
- with High Tension (HT) 88
- with Low Tension (LT) 88

RPM menu 46

S

- Setting a timer 60
- Setting up a gear number display 61
 - automatically determine gear ratios 61
 - manually telling the X Sport when a gear ratio has 61
 - sing a gear position sensor 61
- Setting up the gear number using a gear position s 65
- Setting up the gear ratio display 61
 - Adding a filter to your RPM or wheelspeed signals 64
 - Automatic ratio selection 61, 189
 - Setting up the User selection feature 63
- Setting up the RPM Box 95
- Setup menu structure 41
 - Alarms menu 44
 - Beacon menu 45
 - beacon mask 45
 - Club qualifying mode menu 45
 - Default menu 50
 - Gears menu 47
 - Options menu 49
 - Reset menu 51
 - RPM menu 46
 - Launch 46
 - Pulses 46
 - Red line 46
 - Test menu 50
 - Timer menu 48
 - Units menu 44
 - Wheelspeed menu 47
- Setup mode 37
 - Altering a parameter 39
 - Auto-adjust 40
 - Entering setup mode 39

- Inspect or alter parameters 40
 - Selecting a group 39
 - Selecting a parameter 39
 - Step mode 39
 - Single Outing mode 149
 - Sorting data 148
 - spade connectors 166
 - Standalone mode (SA) 143
 - Outing Report Manager 143
 - Standard pressure sensor 97
 - Connections 97
 - Connector 97
 - Mounting 97
 - Mounting the pressure sensors 98
 - Indirect fitting 98
 - Operating range 97
 - Step mode 39
 - Storing an EOL marker position 57
 - SureSeal connector
 - 2-pin 163
 - Coolant temperature 163
 - Oil temperature 163
 - 3-pin 163
 - Beacon 163
 - RPM 163
 - Wheelspeed 163
- T**
- Tacho input 11
 - Tachometer signals 89
 - Telltale mode 30
 - ORM option 30
 - Telltales Page C 23, 24, 31, 174, 177, 189
 - lap number 23, 24, 174, 177, 189
 - minimum speed 23, 24, 174, 177, 189
 - Page ident letter C 23, 24, 174, 177, 182, 189
 - Telltales Page D 23, 24, 32, 174, 177, 189
 - lap number 23, 24, 174, 177, 189
 - minimum oil pressure 23, 24, 174, 177, 189
 - Page ident letter D 23, 24, 174, 177, 189
 - Telltales Page E 23, 24, 33, 174, 177, 189
 - lap number 23, 24, 174, 177, 189
 - maximum oil temperature 23, 24, 174, 177, 189
 - minimum battery Volts 23, 24, 174, 177, 189
 - Page ident letter E 23, 24, 174, 177, 189
 - Telltales
 - Lap number 20
 - Lap time 20
 - Maximum coolant temperature 20
 - Maximum oil pressure 20
 - Maximum RPM 20
 - Maximum speed 20
 - Minimum battery volts 20
 - Minimum coolant temperature 20
 - Minimum fuel pressure 20
 - Minimum oil pressure 20
 - Minimum speed 20
 - Temperature measurement 99
 - coolant temperature 99
 - mounting the temperature sensors 100
 - oil temperature 99
 - temperature sensor 99
 - accuracy 99
 - connector 99
 - mounting 99
 - operating range 99
 - Test menu 50
 - Test the beacon receiver 70
 - Test the wheelspeed sensor 70, 87
 - Themes page 155
 - Timer
 - Reset menu 51
 - Timer menu 48
 - To open the ORM Download Wizard 157
 - Torque setting
 - dash panel 84
 - mounting the X Sport 83
 - wheelspeed sensor 85, 87
 - Track kit list 69
 - Troubleshooting
 - Lap times 135
 - corrupted 136
 - don't appear 135
 - not working 135

- wrong 136
- Pressure readings
 - wrong 138
- Redline
 - needs to be adjusted 130
- RPM reading
 - cuts out at high RPM 131
 - is occasionally spiky 131
 - is too low 131
- RPM readout
 - flashes at high RPM 131
 - is blank or intermittent 130
 - is unstable 131, 132
- Speed information
 - is corrupted 134
- Speed reading
 - doesn't work at all 132
- Thermocouple
 - readings are noisy 137
- Unstable or absent RPM reading 130
- Water speed
 - appears incorrect 134
- Waterspeed trace
 - is very noisy 134
- Wheelspeed
 - is wrong 133
- Wheelspeed reading
 - seems inaccurate 133
- Wheelspeed sensor
 - errors 132
- X Sport blanks out 129
- X Sport display
 - wrong turbo pressure 138
- X Sport doesn't start up 129
- X Sport is reading
 - half the correct RPM value 130
- X Sport won't go
 - into Setup mode 130
 - into Telltale mode 139

U

- Units menu 44
- Up timer 59
- up/down timer 59
 - Down timer 59
 - Race mode 59
 - Realtime Page A 59
 - Setting a timer 60
 - timer operating modes 59
 - Up timer 59
- USB to serial adapter 13, 143
- USB to serial adapter kit 160
- Using a gear position sensor 61
- Using a GPS input for speed measurement 56
 - enable the GPS functions 56
 - End-of-lap marker 57
 - EOL marker 57
 - GPS zone 58
 - Storing an EOL marker position 57
- Using Club qualifying mode 52
 - Enable Club qualifying mode 52
 - Learn mode 53
 - operating mode 54
 - operating modes 53
 - Resetting CQM stored lap data 55

V

- View Realtime Page parameter settings 26, 29

W

- waterproofed 165
- Wheelspeed measurement 85
 - Wheelspeed sensor 85
- Wheelspeed menu 47
- Wheelspeed sensor 85, 87
 - bracket 87
 - clearance distance 85
 - connector 85
 - gap 87
 - mounting 85
 - torque setting 85

- sensing distance 85
- sensor connections 85
- trigger types 87
- wheelspeed trigger 86
- wheelspeed sensor 70
 - adjusted correctly 70
- Wiring notes 81

X

- X Sport and
 - MBE ECU 173
 - Pectel ECU 177
- X Sport connections
 - 2-pin SureSeal 163
 - 3-pin SureSeal 163
 - 4mm ring tags 167
 - spade connectors 166
 - SureSeal 162
 - waterproofing SureSeal connectors 165
- X Sport dimensions 82
- X Sport display fields 23, 24
- X Sport ECU loom 169, 177, 186
- X Sport modes
 - alarm thresholds 26
 - MBE ECU 173
 - power up mode 26
 - power up selftest 26
 - Race mode 26
 - Realtime mode 26
 - Setup mode 26
 - Software version 26
 - Telltale mode 26

Contact information

For more information about Pi products and details of worldwide authorised agents, please contact:

Pi Research

Brookfield Motorsports Centre
Twentypence Road
Cottenham
CAMBRIDGE
CB4 8PS
UK

Customer Support Tel +44 (0) 1954 253600
Fax +44 (0) 1954 253601

Pi Research, Inc.

8250 Haverstick
Suite #275
Indianapolis
IN 46240
USA

Tel +1 (317) 259-8900
Fax +1 (317) 259-0137

www.pixpress.com